

---

# Environmental & Security Solutions

Optimize Data Center Environments  
and Protect IT Assets

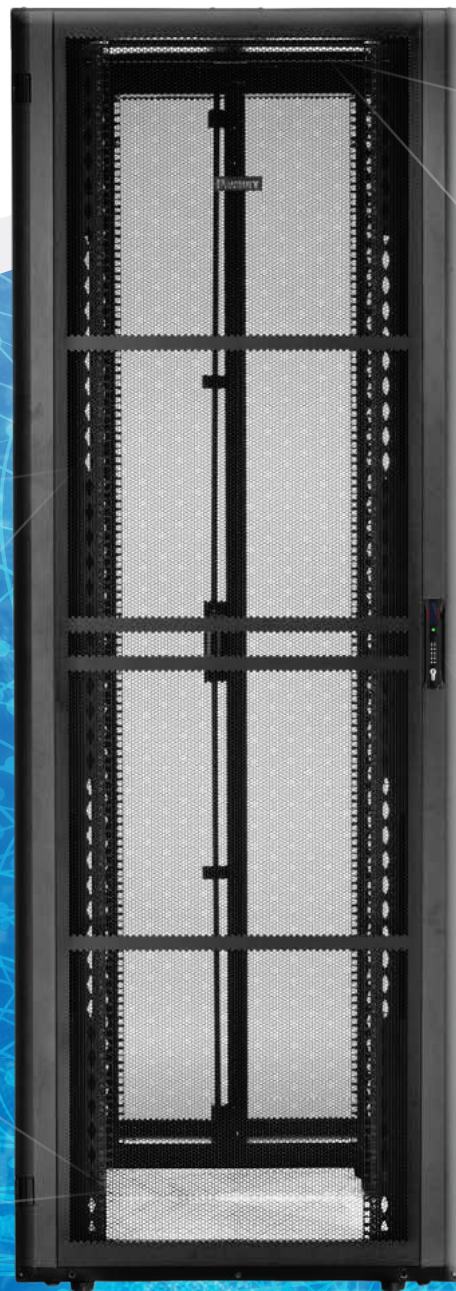

# Ensure Peak Efficiency and Security for Your Data Center

In today's fast-paced data center environment, maintaining efficiency and security is crucial. Our innovative critical power solutions, including real-time monitoring sensors and intelligent rack security handles, ensure your data center operates seamlessly and securely. Explore how our integrated systems can elevate your operations and provide the tools you need to limit risk.

## Key Solutions

### Real-Time Environmental Monitoring

Customizable thresholds and event notifications safeguard against downtime threats



### Easy Integration

Plug-and-play with Panduit G5/G6 iPDU and UPS Systems

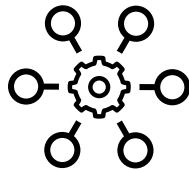

### Intelligent Rack Security Handles

Peace of mind through managed access control and real-time alerts



### Comprehensive Data Analysis

Leverage DCIM software to gain insights and drive data-informed decisions



# Comprehensive Environmental Monitoring

Optimize your data center’s mission critical environment with real-time monitoring solutions from Panduit. Our sensors track temperature, humidity, and potential leaks to ensure optimal conditions. Leverage these insights for data-driven decision making and improved operational efficiency.

### Features

Real-time temperature, humidity, and leak detection

Customizable alerts and thresholds

Easy integration with DCIM software

G5/G6 iPDU and UPS firmware self-identification

Quick connect with RJ45 plug



Spot Fluid Leak Sensor



Intelligent Rack Security Handle 3-Temperature and Door Sensor



Sensor Hub Kit



Rope Fluid Leak Sensor Kit



Optimize Your Data Center

# Intelligent Rack Access Control

Secure your IT assets with our intelligent advanced rack security handles which feature an integrated humidity sensor and provide managed access control and real-time alerts to ensure critical infrastructure is protected.

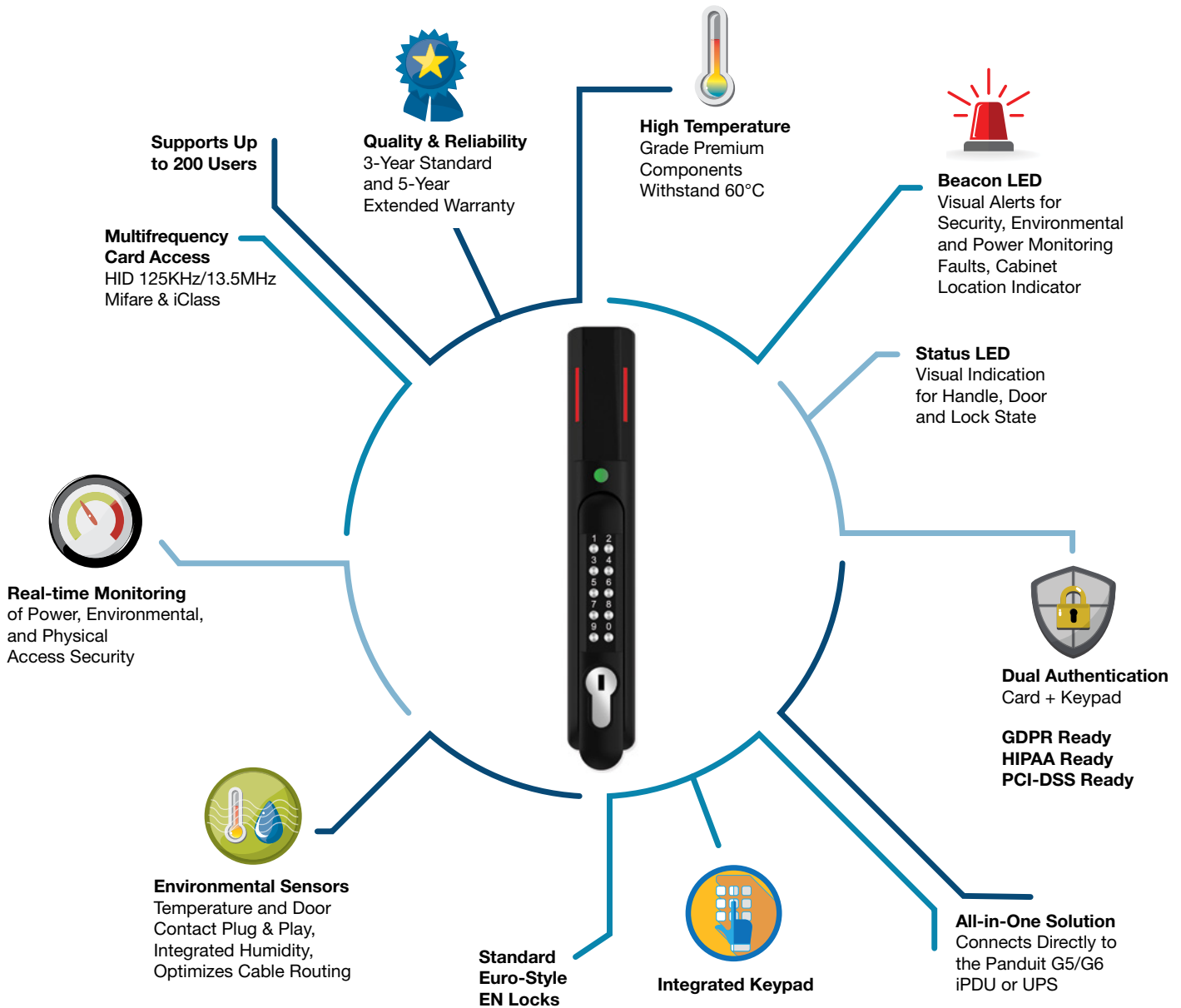

Read the Guide

# Security Diagrams

## Security Handle

**Features**

- Up to 200 users
- Multifrequency card access
- HID 125 kHz/13.5 MHz, Mifare and iClass
- Dual authentication (keypad version)

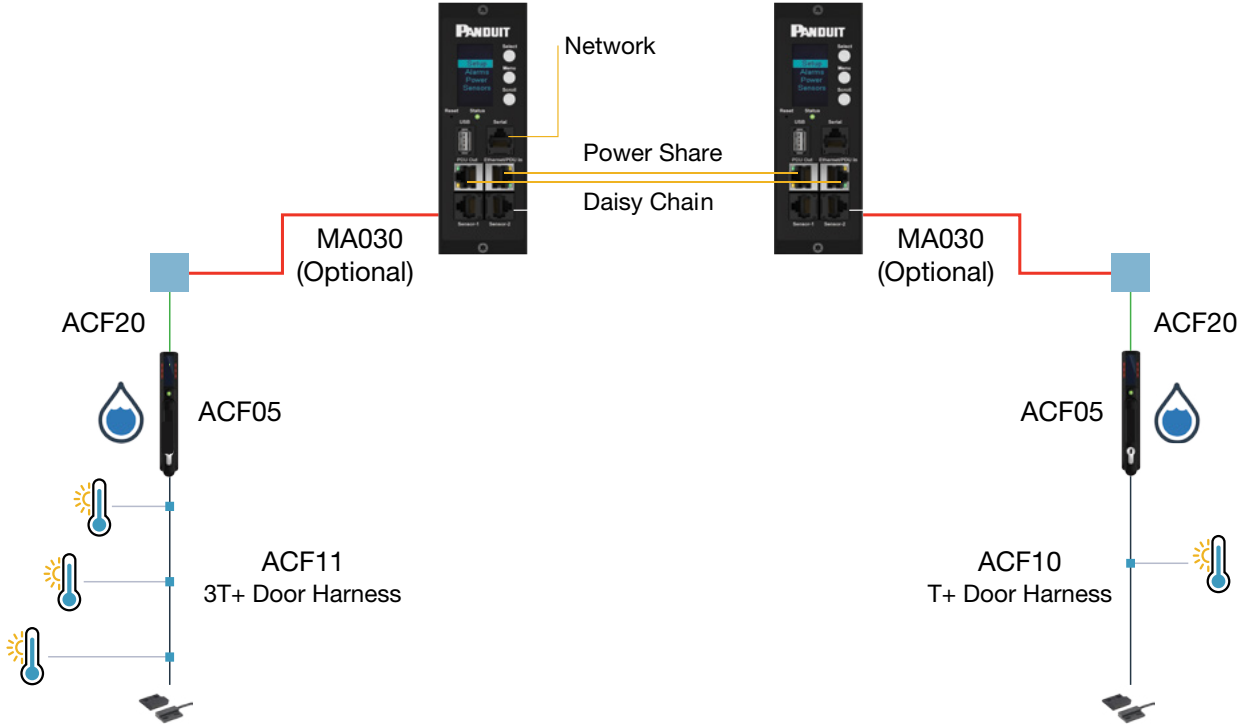
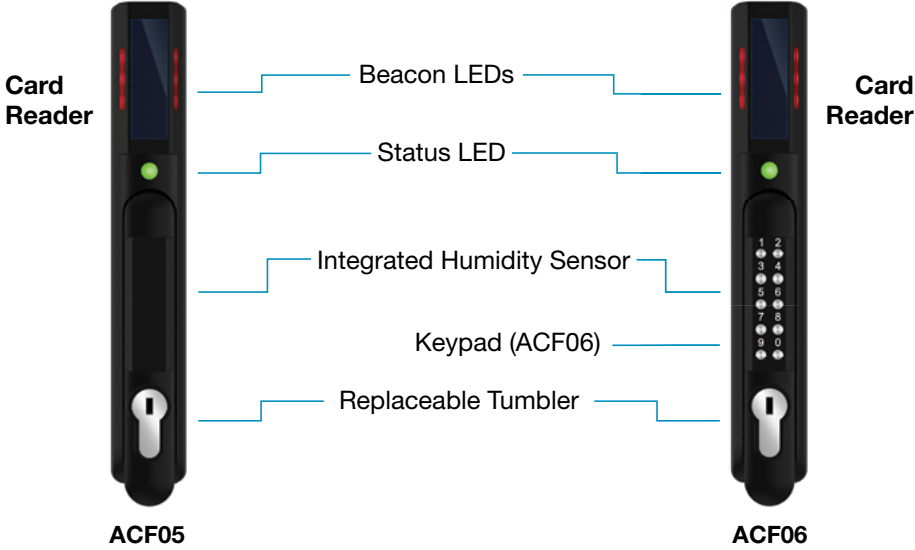

[View All Products](#)

# Application Diagrams

Discover how our environmental sensors and rack security solutions can transform your data center operations. Consult with our critical power specialist today and take the first step toward a more efficient and secure data center.

## UPS

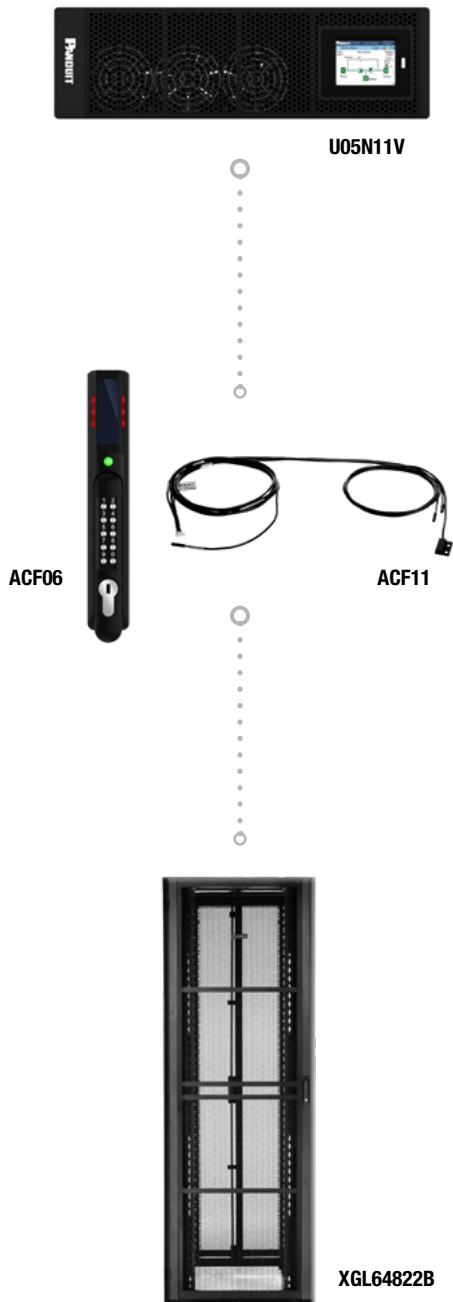

## PDU

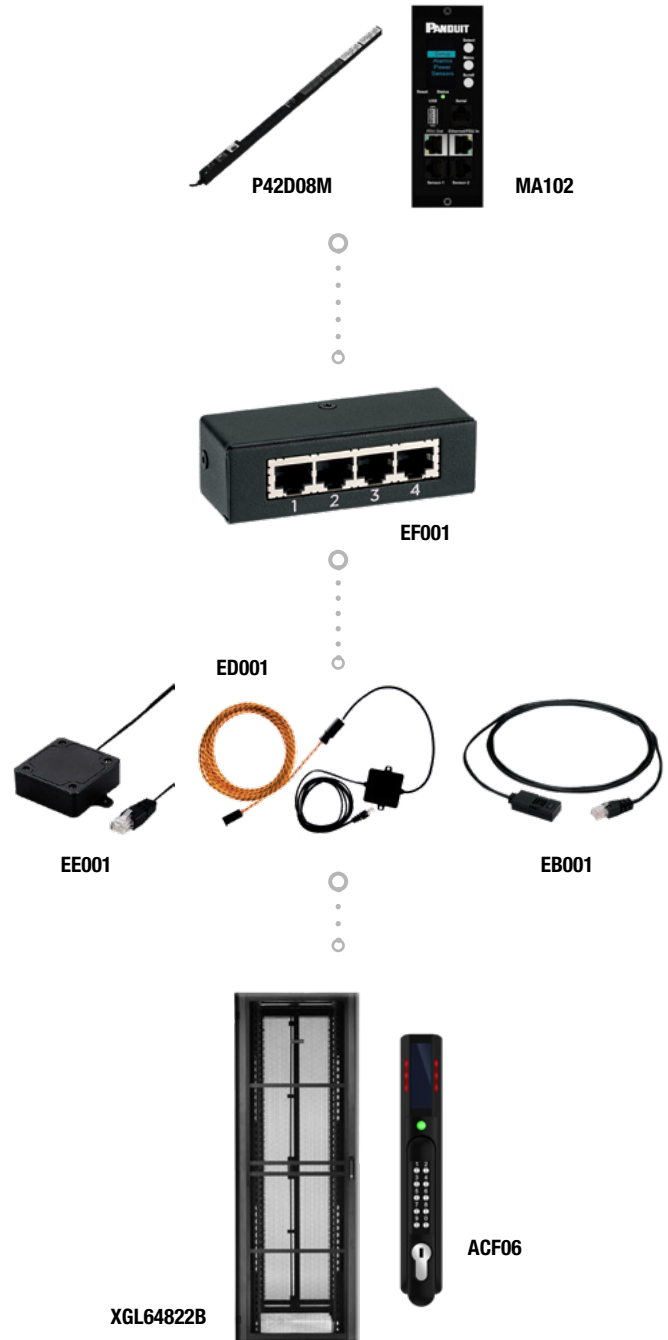

# Holistic Critical Power Solution

## Seamless Integration and Data Analytics

Our solutions seamlessly integrate with our G5/G6 iPDU and UPS systems for a comprehensive data center management approach. Leverage third-party DCIM software for detailed data analysis, driving informed decisions and enhancing overall efficiency and uptime.

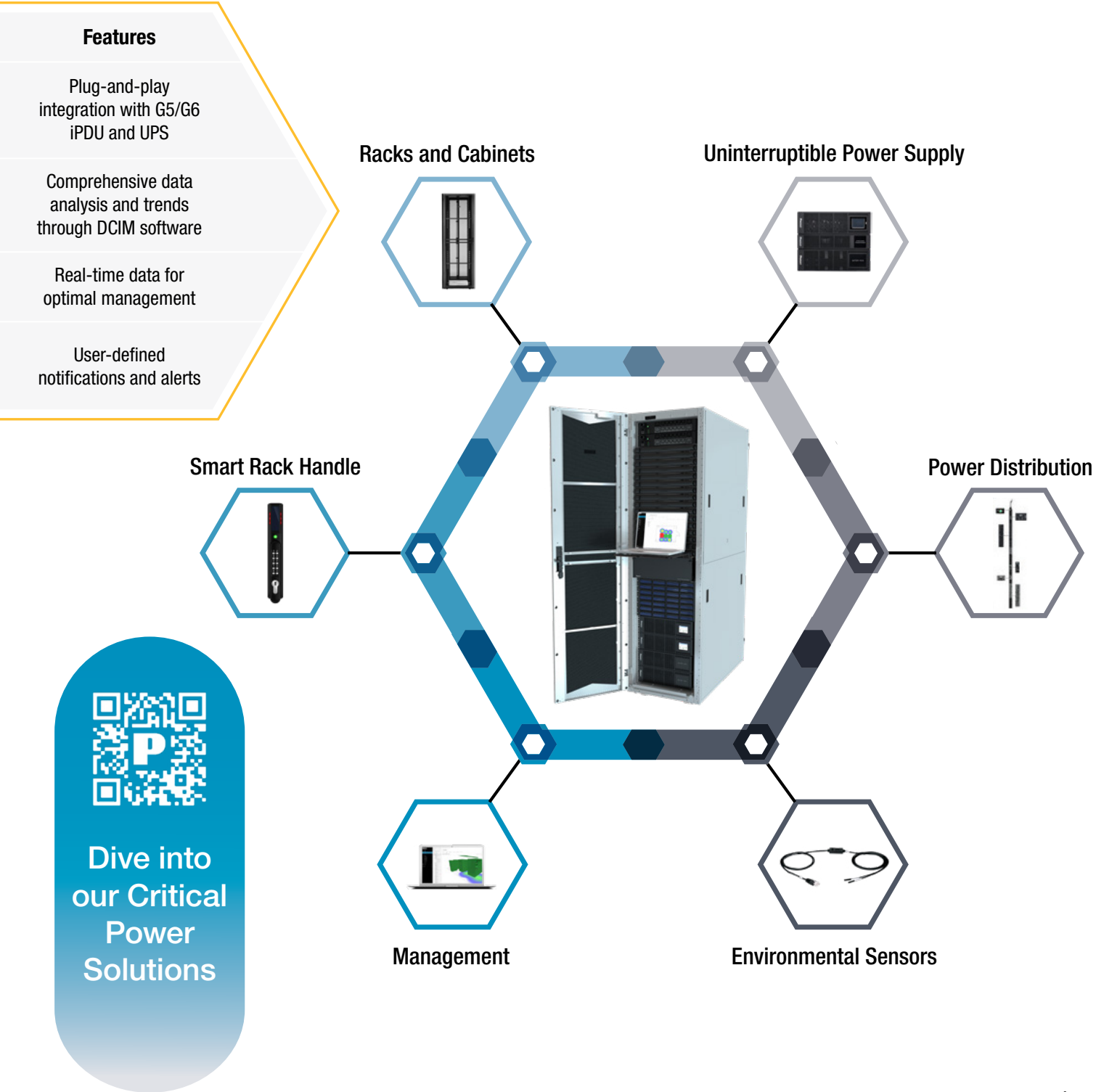

# PDU Environmental Sensors

Transform your data center's environmental rack monitoring and power distribution with our comprehensive suite of plug and play, digital sensors and accessories. Where each solution is engineered to meet specific monitoring and power management needs.



### Temperature Sensor (EA001)

Keep a precise check on temperature levels and receive threshold alerts on critical values to ensure you have optimal conditions to protect your IT equipment's performance and longevity.



### Temperature & Humidity Sensor (EB001)

Dual monitoring capability notifies you when ideal temperature and humidity levels are exceeded, safeguarding your equipment from environmental stress.



### 3-in-1 Temperature & Humidity Sensor (EC001)

An integrated solution to monitor humidity and temperature at the top, middle and bottom of a rack, this versatile sensor offers temperature and humidity in one compact unit.



### Rope Leak Detector (ED001)

Protect your assets from water damage with this sensitive and expansive leak detection system, perfect for covering large areas.



### Spot Leak Detector (EE001)

Rapidly identify and address specific leak-prone spots, preventing damage and downtime with pinpoint accuracy.



### 3-Sensor Input Hub (EF001)

Centralize and streamline your monitoring by connecting multiple sensors to a single hub, simplifying management and data analysis.



# Rack and Security Access Control



## Dry Contact Input (ACC01)

Integrate a wide range of external sensors and devices into your monitoring system, enhancing flexibility and control.



## Door Contact Switch (ACA01)

Secure your critical areas with this switch that alerts you whenever protected doors are accessed.



## Auto Light Bar (ACD01)

Illuminate your cabinets automatically upon opening, enhancing visibility and convenience during maintenance or inspection.



## Intelligent Rack Security Handle with Humidity Sensor (ACF05)

Remote management and protection of data center racks from unauthorized users. Have peace of mind knowing IT assets are secure.



## Intelligent Rack Security Handle with Humidity Sensor and Keypad (ACF06)

Further safeguard your IT equipment from unauthorized users with the integrated keypad to enable dual authentication.



## Intelligent Rack Security Handle Temperature and Door Sensor (ACF10)

Minimize your cable clutter in the rack by integrating this temperature sensor through the Intelligent Rack Security Handle.

# Rack and Security Access Control



## Intelligent Rack Security Handle 3-Temperature and Door Sensor (ACF11)

Minimize thermal risk by integrating this 3-temperature and 1-door sensor through the Intelligent Rack Security Handle.



## Intelligent Rack Security Handle Harness (ACF20)

Simple-to-use RJ45 plug to JST plug connects the Intelligent Rack Security Handle to the G5/G6 iPDU or UPS.



## Intelligent Rack Security Handle Patch Cord Extension (MA30)

Use this convenient RJ45 patch cord to extend the reach of the rack security handle to the iPDU or UPS.

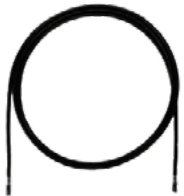

## G5 iPDU Power Share Patch Cord (RJ45 Male to R45 Male) (MA031)

Maximize your IT efforts by using this patch cord to daisy-chain up to four G5 iPDUs.



## Security Access HID Cards 125 kHz (10 Pack) (CRD-02-10PK)

Available in convenient packs of 10 for use with the high-frequency card reader option on the Intelligent Rack Security Handle.



## Security Access HID Cards 13.56 MHz (10 Pack) (CRD-03-10PK)

Available in convenient packs of 10 for use with the low-frequency card reader option on the Intelligent Rack Security Handle.

# Connect with Our Experts

Discover today how Panduit environmental sensors and intelligent rack security solutions can transform your data center operations.

Consult with our critical power specialist today and take a step towards a more efficient and secure data center.

Contact us: **800-777-3300**  
or **cx@panduit.com**



Scan to  
Contact Us

---

## Our most important connection is with you.

We have the knowledge and experience to help you make the most of your infrastructure investment.

**Let's Connect**

**[www.panduit.com/contact-us](http://www.panduit.com/contact-us)**

**PANDUIT®**