

Wall Mount Enclosures for Passive Optical LAN

SPECIFICATIONS

The enclosures shall be designed to mount on a wall or pole, and shall be compliant to IP55 standards. The enclosures shall be multi-functional to allow for mechanical splicing, fusion splicing, or pre-terminated components. The enclosures shall include options for management of multiple fiber optic cables into and out of the enclosure, and shall be available in multiple sizes to allow for scalability based on potential user demand.

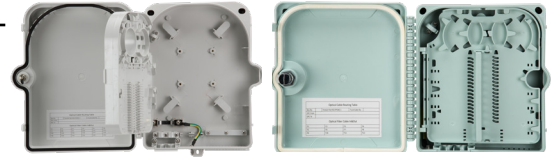

TECHNICAL INFORMATION

| Attributes: | Part Number | FASSCZAG* Capacity | FPONEAP12** Capacity | Height in. (mm) | Width in. (mm) | Depth in. (mm) |
|------------------------|--|--------------------|----------------------|-----------------|----------------|----------------|
| | FPONE1 | 12 | - | 233 | 200 | 63 |
| | FPONE2 | 12 | - | 317 | 235 | 100 |
| | FPONE3 | 24 | 2 | 420 | 350 | 110 |
| Relative humidity: | <90% | | | | | |
| Ingress protection: | IP55 | | | | | |
| Bend radius curvature: | 40 mm | | | | | |
| Temperature ranges: | Working temperature: - 40°C to 60°C Storage temperature: - 40°C to 60°C | | | | | |

APPLICATIONS

For use in passive optical networks to house, protect, and manage optical splitters and their breakout fiber optic cabling.

ORDERING INFORMATION

| Part Number | Description |
|-------------|---|
| FPONE1 | Fiber Enclosure for Passive Optical LAN, 233mm x 200mm x 63mm |
| FPONE2 | Fiber Enclosure for Passive Optical LAN, 317mm x 235mm x 100mm |
| FPONE3 | Fiber Enclosure for Passive Optical LAN, 420mm x 350mm x 110mm |
| FASSCZAG* | Simplex SC-APC Adapter (Sold as FASSCZAG-L, a pack of 50) |
| FPONEAP12 | Fiber PON Enclosure Adapter Panel with 12 Ports for FASSCZAG Adapters |

*Add-L to indicate bulk packages of 50 to reduce single-use plastic

Note 1: FPONEAP12 accepts 12 FASSCZAG each

Note 2: FPONEAP12 is not compatible with any Opticom® products.

Wall Mount Enclosures for Passive Optical LAN

ENGINEERING DRAWINGS

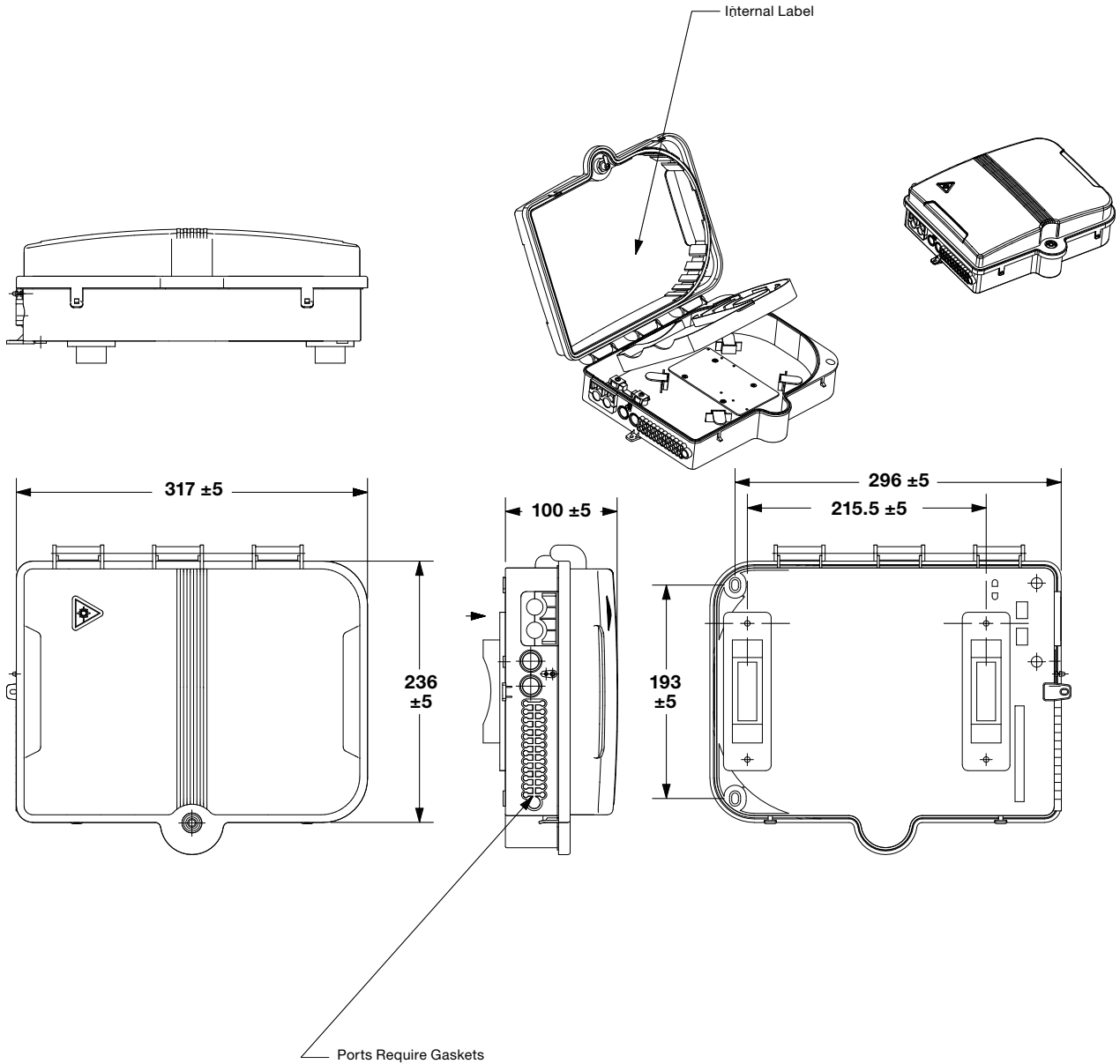

Dimensions are in inches. [Dimensions in brackets are metric].

WORLDWIDE SUBSIDIARIES AND SALES OFFICES

PANDUIT US/CANADA
Phone: 800.777.3300

PANDUIT EUROPE LTD.
London, UK
Phone: 44.20.8601.7200

PANDUIT SINGAPORE PTE. LTD.
Republic of Singapore
Phone: 65.6305.7575

PANDUIT JAPAN
Tokyo, Japan
Phone: 81.3.6863.6000

PANDUIT LATIN AMERICA
Guadalajara, Mexico
Phone: 52.33.3777.6000

PANDUIT AUSTRALIA PTY. LTD.
Victoria, Australia
Phone: 61.3.9794.9020

For a copy of Panduit product warranties, log on to www.panduit.com/warranty

PANDUIT[®]

For more information
Visit us at www.panduit.com
Contact Customer Service by email: cs@panduit.com
or by phone: 800.777.3300

© 2024 Panduit Corp.
ALL RIGHTS RESERVED.
FBSP264-WW-ENG
3/2024