

THIS COPY IS PROVIDED ON A RESTRICTED BASIS AND IS NOT TO BE USED IN ANY WAY DETRIMENTAL TO THE INTERESTS OF PANDUIT CORP.

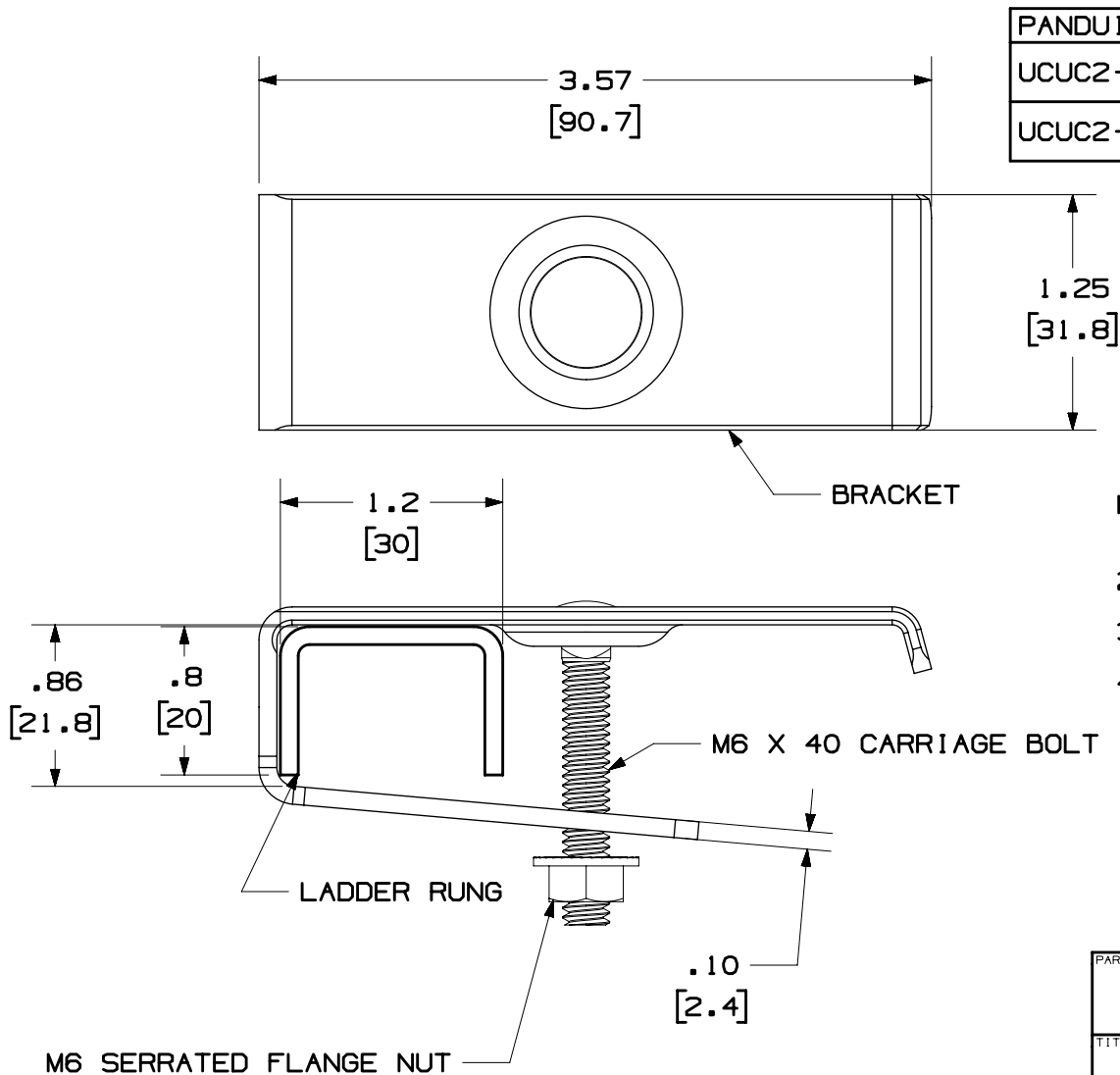

PANDUIT P/N	MATERIAL	WEIGHT/PC
UCUC2-V316	316L STAINLESS STEEL	0.26 lbs [118 g]
UCUC2-VC	GALVANIZED STEEL	0.26 lbs [118 g]

NOTES:

1. PRIMARY DIMENSIONS IN ENGLISH. DIMENSIONS IN [] ARE METRIC.
2. FOR USE WITH SQUARE OR U-CHANNEL WITH NO SLOTS.
3. LADDER RUNG DIMENSIONS ARE FOR REFERENCE
4. EACH ASSEMBLY INCLUDES:
(1) BRACKET
(1) M6 X 40MM CARRIAGE BOLT
(1) M6 SERRATED FLANGE NUT

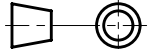
PART NUMBER		UCUC2-V316 AND UCUC2-VC	
TITLE		UNICLIP U-CHANNEL TYPE BRACKET UCUC2 STYLE	
		CUSTOMER DRAWING	
ITEM REVISION NAME		00594EAA/01	
DATASET FILE NAME		00594EAA_DC/01A	
		THIRD ANGLE PROJECTION	
MATERIAL		SEE TABLE	
DRAWING NUMBER		00594EAA_DC	
REV	DATE	BY	CHK
00A	12/12/19	ACC	FLD
01A	12/18/19	ACC	FLD
REV	DATE	BY	CHK
00A	12/12/19	ACC	FLD
01A	12/18/19	ACC	FLD

REV	DATE	BY	CHK	APR	DESCRIPTION	ECN
00A	12/12/19	ACC	FLD		INITIAL RELEASE	
01A	12/18/19	ACC	FLD	JADE	REMOVED OLD NOTES 3 AND 4. UPDATED BRACKET DESIGN RELEASED TO PRODUCTION	056632

PANDUIT

SHEET 1 OF 1

A