

# Pan-Punch® 110 Punchdown System

## SPECIFICATIONS

The 110 Punchdown System shall provide deep channels in each base that allow jacketed cable to be routed within 0.5 inches of the point of wire termination. Each base shall have color coded wire strips that assist in wire sorting and troubleshooting. Connecting blocks shall have test access through the housing, allowing testing of individual contacts without removing the wire. The jumper troughs shall have rounded edges that eliminate sharp bends in cable and help maintain Category 5e minimum bend radius.

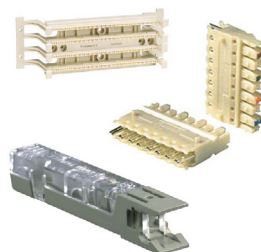

## TECHNICAL INFORMATION

<b>Electrical performance:</b>	Exceeds all channel and component requirements of ANSI/TIA 568.2-D Category 5e standard
<b>Mechanical performance:</b>	Meets IEC 60352-4 requirements; can withstand repeated terminations up to 200 cycles

## KEY FEATURES AND BENEFITS

<b>Compatibility:</b>	Compatible with existing 110 installations
<b>Deeper cable channel in the base:</b>	Allows cable jacket end to be within 1/2" from IDC connection per TIA-568 requirements
<b>Field terminable patch cord connector:</b>	Assemble patch cords in the field to improve cable management, no tools required
<b>Metal contact retention in connecting block:</b>	Contact is positively retained in the one piece connector housing
<b>Legs are molded as part of the base:</b>	Provides a sturdy base that cannot be accidentally removed from its mounting
<b>Base has TIP colors on wire strip:</b>	Easy 25-pair installation; assists in long term maintenance
<b>Connecting Block has RING colors for wiring identification:</b>	Easy installation of 4-pair cabling

## APPLICATIONS

The Pan-Punch 110 Punchdown System is a versatile punchdown system used to connect, manage, identify and cross-connect communications equipment wiring in telecommunications closets and main distribution frames. The Pan-Punch 110 Punchdown System is commonly used in both voice networks and data local area networks designed for use with unshielded twisted pair copper wire and cable. It can be used on jobs as small as 100-pair.

Large projects can use 19" rack mount panels. Rack mount panels are available in 200-pair increments. A typical Pan-Punch System installation uses one base to connect the communication equipment cabling and a different base to connect workstation cabling. Equipment and workstation bases are interconnected/cross-connected with jumpers and/or patch cords.

### Pan-Punch 110 Bases

<b>100-pair with legs:</b>	P110BW100-X
<b>100-pair without legs:</b>	P110B100-X

### Pan-Punch Jumper Troughs

<b>With legs:</b>	P110JTW-X
<b>Without legs:</b>	P110JT-X

### Pan-Punch Connecting Blocks

<b>4-pair:</b>	P110CB4-XY
<b>5-pair:</b>	P110CB5-XY

### Pan-Punch Field Terminable 110 Patch Cord Connector

<b>1-pair:</b>	P110PC1-XY
<b>2-pair:</b>	P110PC2-XY
<b>4-pair:</b>	P110PC4-XY

### Pan-Punch Patch Cords

<b>1-pair:</b>	P110PC1IG*MY
<b>1-pair to RJ45:</b>	P110PC1IGD*MY
<b>4-pair:</b>	P110PC4IG*MY
<b>4-pair to RJ45-T568A:</b>	P110PC4IG*MAY
<b>4-pair to RJ45-T568B:</b>	P110PC4IG*MBY

### Pan-Punch Rack Mount Panels

<b>Two 100 pair bases without troughs (2 RU):</b>	P110B100R2Y
<b>Two 100 pair bases with troughs (4 RU):</b>	P110B100R4WJY

### Punchdown Tools

<b>5-pair:</b>	PDT110M
<b>Single:</b>	PDT110
<b>Wire stripping tool:</b>	CJAST

\*Meter lengths 1, 2, 3, or 5 meters  
-X indicates bulk packs with 10 pieces per package to reduce single-use plastic

# Pan-Punch® 110 Punchdown System

## CONNECTOR BLOCK TEST RESULTS

Performance Test	Test Method	16 MHz		100 MHz	
		Required Performance	Typical Test Results (dB)	Required Performance	Typical Test Results (dB)
NEXT	TIA/EIA-568-A-5	> 58.9	62.8	> 43.0	46.9
FEXT		> 51.0	67.2	> 35.1	51.1
Attenuation		< 0.20	0.004	< 0.40	0.02
Return Loss		< 35.0	42.5	< 20.0	27.1

Contact customer service for cable brand specific channel test results.

Mechanical Test	Test Method	Measurement	Typical Test Results
Vibration	IEC 512-6d	Circuit Resistance Change (mOhms)	< 1
Shock	IEC 512-6c	Contact Disturbance (microsecond)	< 1
Durability	IEC 512-9a	Circuit Resistance Change (mOhms)	< 5

Electrical Test	Test Method	Measurement	Typical Test Results
Low Level Circuit Resistance	IEC 512-2a	Resistance (mOhms)	< 5
Dielectric Withstand Voltage	IEC 512-4a	1000 VAC, 1 minute	Passed
Insulation Resistance	IEC 512-3a	Resistance (MOhms)	> 10000

Electrical Test	Test Method	Measurement	Typical Test Results
Temperature Life	IEC 512-9b	Circuit Resistance Change (mOhms)	< 1
Humidity	IEC 512-11c		< 2
Thermal Shock	IEC 512-11d		< 5
Climatic Sequence	IEC 512-11a		
Flowing Mixed Gas Corrosion	IEC 512-11g		

Part Number	Pairs	Dimension for "A"	Dimension for "B"
P110CB4	OEC 512-11c	1.196 (30.38)	1.050 (26.67)
P110CB5	OEC 512-11d	1.496 (38.00)	1.350 (34.29)

## ENGINEERING DRAWINGS

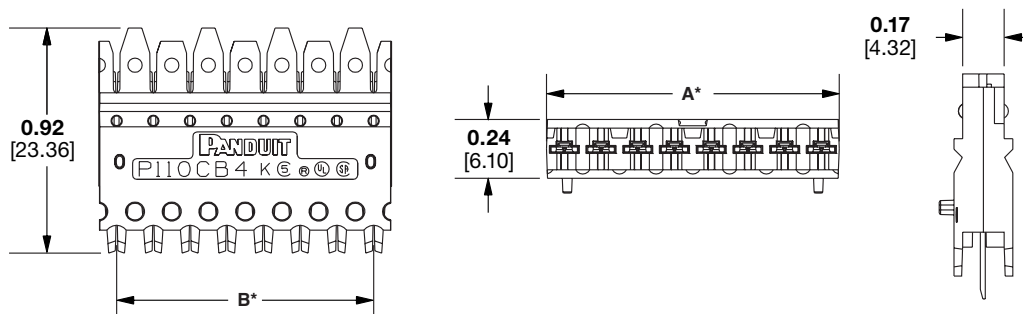

Dimensions are in inches. [Dimensions in brackets are metric].

### WORLDWIDE SUBSIDIARIES AND SALES OFFICES

PANDUIT US/CANADA  
Phone: 800.777.3300

PANDUIT EUROPE LTD.  
London, UK  
Phone: 44.20.8601.7200

PANDUIT SINGAPORE PTE. LTD.  
Republic of Singapore  
Phone: 65.6305.7575

PANDUIT JAPAN  
Tokyo, Japan  
Phone: 81.3.6863.6000

PANDUIT LATIN AMERICA  
Guadalajara, Mexico  
Phone: 52.33.3777.6000

PANDUIT AUSTRALIA PTY. LTD.  
Victoria, Australia  
Phone: 61.3.9794.9020

For a copy of Panduit product warranties, log on to [www.panduit.com/warranty](http://www.panduit.com/warranty)

# PANDUIT®

For more information  
Visit us at [www.panduit.com](http://www.panduit.com)  
Contact Customer Service by email: [cs@panduit.com](mailto:cs@panduit.com)  
or by phone: 800.777.3300

© 2024 Panduit Corp.  
ALL RIGHTS RESERVED.  
COSP540-WW-ENG  
7/2024