

THIS COPY IS PROVIDED ON A RESTRICTED BASIS AND IS NOT TO BE USED IN ANY WAY DETRIMENTAL TO THE INTERESTS OF PANDUIT CORP.

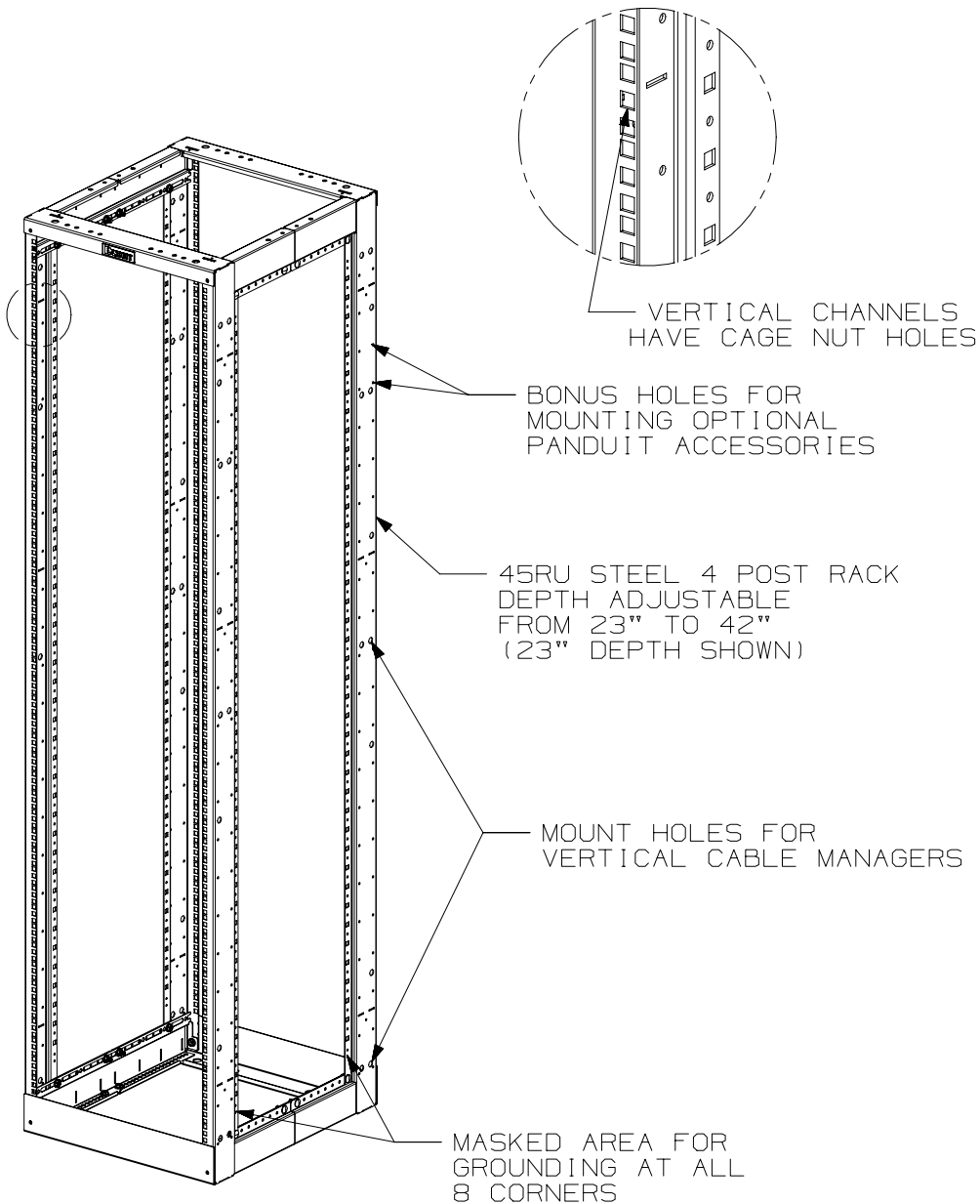

PANDUIT PART NO.	WEIGHT
AR4PCN	65.1 LBS
AR4PCNWH	29.5 Kg

NOTES:

- VISIT OUR ON-LINE CATALOG AT WWW.PANDUIT.COM FOR A LIST OF CURRENT PARTS APPLICABLE FOR USE WITH THIS PRODUCT.
- DIMENSIONS IN PARENTHESIS ARE METRIC.
- RACK DEPTH IS ADJUSTABLE FROM 23" TO 42" AT 1/2" INCREMENTS.
- CAN BE USED WITH ANY EIA STANDARD COMPONENT IN ADDITION TO ALL PANDUIT HORIZONTAL CABLE MANAGEMENT AND PATCH PANEL PRODUCTS.
- 45 AVAILABLE RACK SPACES.
- EIA UNIVERSAL STANDARD HOLE PROGRESSION ON FRONT AND REAR CHANNELS. .625", .625", .500", .625", .625", .500"...ETC.
- ALL RACKS WILL HAVE NUMBERS UP ORIENTATION (RU "01" ON BOTTOM, RU "45" ON TOP).
- RU SPACING NUMBERS ARE CLEARLY PRINTED ON MOUNTING RAILS.
- ALL ASSEMBLY HARDWARE INCLUDED:
  - (2) 84" TALL WELDED RACK FRAME WITH CAGE NUT MOUNT HOLES
  - (4) ADJUSTABLE DEPTH MOUNT BRACKETS
  - (1) HARDWARE KIT
- EASY ASSEMBLY, ONE WRENCH NEEDED TO INSTALL CARRIAGE BOLTS INTO IN ALL 8 CORNERS.
- FULLY BONDED STRUCTURE WHEN ASSEMBLED PER INSTRUCTIONS.
- LOAD RATING - 2000 LBS.

PART NUMBER		AR4PCN / AR4PCNWH	
TITLE		STEEL 4 POST RACK, 45RU CAGE NUT RAILS, ADJUSTABLE DEPTH FROM 23" TO 42"	
ITEM REVISION NAME		CUSTOMER DRAWING	
DATASET FILE NAME		00448EAD/02	
MATERIAL		STEEL	
DRAWING NUMBER		00448EAD-DC	
DRAWN BY		TJV	
DATE		7-10-20	
CHK		RYB	
SCALE		NONE	
SHEET		SHEET 1 OF 3	
SIZE		A	

REV	DATE	BY	CHK	APR	DESCRIPTION	ECN
02B	2-8-22	TWV	KZU	JEFK	UPDATED GROUNDING MASKED AREA NOTE	M09000LA/07
02A	6-22-21	RYB	KRKE		ADDED RACK EIA DIMENSIONS	M09000LA/06

A-SIZE CUSTOMER

THIS COPY IS PROVIDED ON A RESTRICTED BASIS AND IS NOT TO BE USED IN ANY WAY DETRIMENTAL TO THE INTERESTS OF PANDUIT CORP.

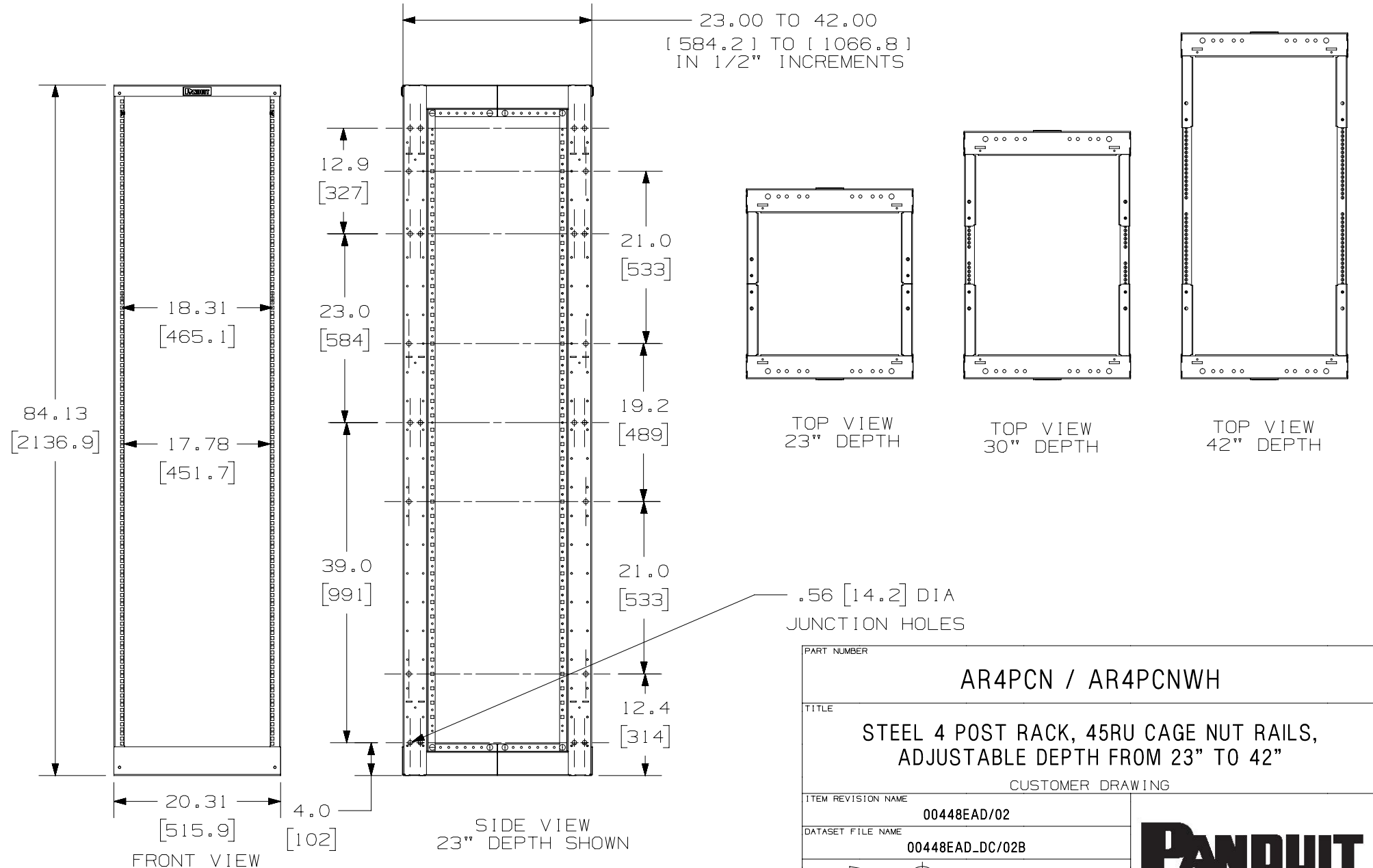

PART NUMBER		AR4PCN / AR4PCNWH	
TITLE		STEEL 4 POST RACK, 45RU CAGE NUT RAILS, ADJUSTABLE DEPTH FROM 23" TO 42"	
ITEM REVISION NAME		CUSTOMER DRAWING	
DATASET FILE NAME		00448EAD-DC/02B	
MATERIAL		STEEL	
DRAWN BY		TWW	
DATE		7-10-20	
CHK		RYB	
SCALE		NONE	
DRAWING NUMBER		00448EAD-DC	
SHEET		3HEET 2 OF 3	
SIZE		A	

REV	DATE	BY	CHK	APR	DESCRIPTION	ECN
02B	2-8-22	TWV	KZU	JEFK	SEE SHEET ONE FOR REVISIONS	M09000LA/07
02A	6-22-21	RYB	KRKE		SEE SHEET ONE FOR REVISIONS	M09000LA/06

A-SIZE CUSTOMER

THIS COPY IS PROVIDED ON A RESTRICTED BASIS AND IS NOT TO BE USED IN ANY WAY DETRIMENTAL TO THE INTERESTS OF PANDUIT CORP.

2

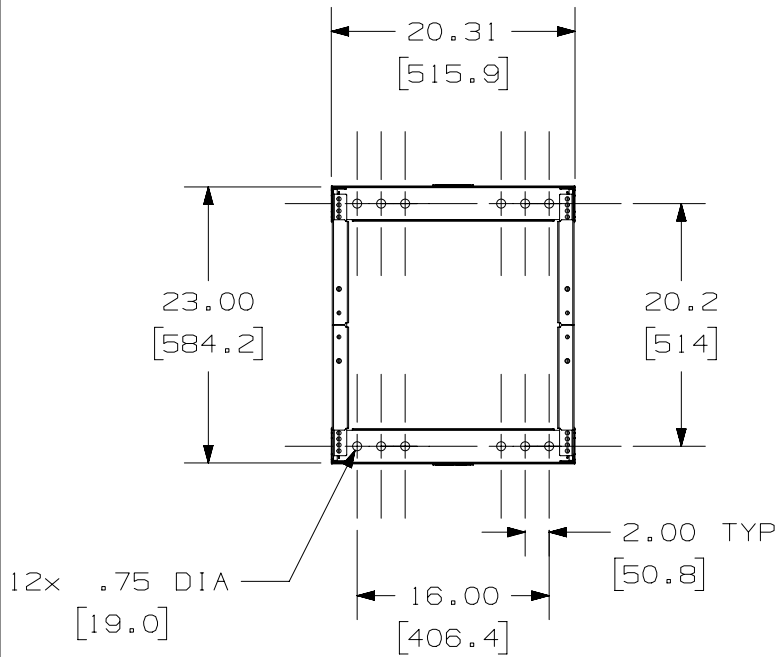

1

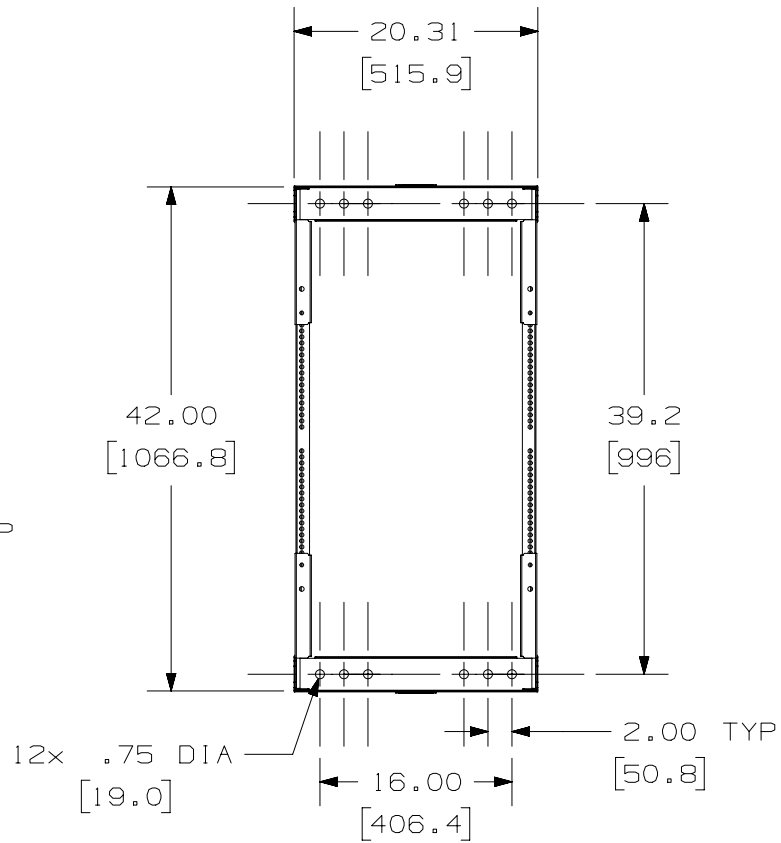

FLOOR FOOTPRINT AT 23" MINIMUM DEPTH

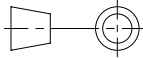

FLOOR FOOTPRINT AT 42" MAXIMUM DEPTH

PART NUMBER		AR4PCN / AR4PCNWH	
TITLE		STEEL 4 POST RACK, 45RU CAGE NUT RAILS, ADJUSTABLE DEPTH FROM 23" TO 42"	
CUSTOMER DRAWING			
ITEM REVISION NAME		00448EAD/02	
DATASET FILE NAME		00448EAD_DC/02B	
 THIRD ANGLE PROJECTION			
MATERIAL		STEEL	
DRAWING NUMBER		00448EAD-DC	
DRAWN BY	DATE	CHK	SCALE
TWV	7-10-20	RYB	NONE
SHEET 3 OF 3		A	

REV	DATE	BY	CHK	APR	DESCRIPTION	ECN
02B	2-8-22	TWV	KRKE	JEFK	SEE SHEET ONE FOR REVISIONS	M09000LA/07
02A	6-22-21	RYB	KRKE		SEE SHEET ONE FOR REVISIONS	M09000LA/06

2

1

A-SIZE CUSTOMER

B

B

A

A