

THIS COPY IS PROVIDED ON A RESTRICTED BASIS AND IS NOT TO BE USED IN ANY WAY DETRIMENTAL TO THE INTERESTS OF PANDUIT CORP.

PANDUIT P/N	WEIGHT
PWBCB6**	1.0 LBS/EACH (453.59g)/EACH

NOTES:

1. DIMENSIONS IN [] ARE METRIC.
2. PART INCLUDES 1 BRACKET
3. PART WORKS WITH ALL 6" OR SMALLER WIDE WIRE BASKETS.
4. BRACKET ACCEPTS UP TO 5/16" OR 8mm CUSTOMER SUPPLIED MOUNTING HARDWARE
5. BASKETS ARE MOUNTED TO CANTILEVER BRACKET WITH 2 PWBHK**. (SOLD SEPARATELY).
6. **= BL (BLACK POWDER COAT), WH (WHITE POWDER COAT), OR EZ (CLEAR ZINC)
7. ALL MATERIALS AND COMPONENTS USED MEET THE MATERIAL RESTRICTIONS OF RoHS (EUROPEAN DIRECTIVE 2011/65/EC ON THE RESTRICTION OF HAZARDOUS SUBSTANCES) AS PROPOSED BY THE RoHS TECHNICAL ADAPTATION COMMITTEE.

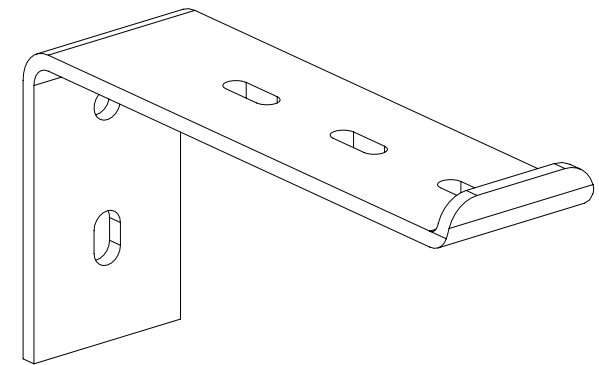
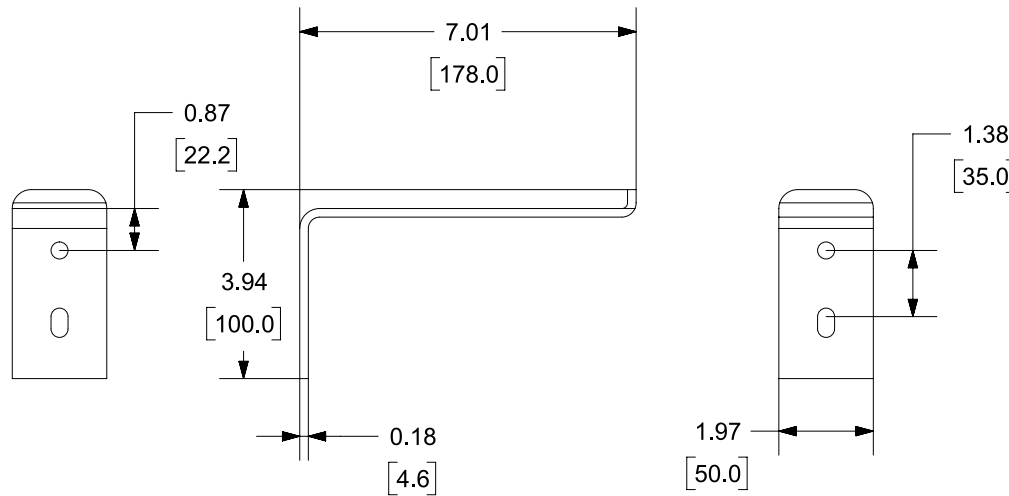

TITLE		WIRE BASKET CANTILEVER BRACKET 6" [150mm]	
ITEM REVISION NAME		CUSTOMER DRAWING	
DATASET FILE NAME		00510EPF/02	
		00510EPF_DC/02C	
MATERIAL		C.R.S.	
DRAWN BY		DATE	CHK
JSP	6/2/21	WJM	SCALE
DESCRIPTION		NONE	
ECN		DRAWING NUMBER	
00510EPF-DC		00510EPF - DC	
REV		SIZE	
SHEET 1 OF 1		A	

REV	DATE	BY	CHK	APR	DESCRIPTION	ECN
02C	12-14-23	SAT	DWR	EB	B. UPDATED TITLE.	00510EPF-DC
02B	3/7/22	JSP	DWR	ML	A. ADD NOTE 3-7	00510EPF-DC
02A	6/2/21	JSP	WJM	ML	INITIAL RELEASE	00510EPF-DC

A-SIZE CUSTOMER