

INSTALLATION INSTRUCTIONS FOR UPS 2-POST RACK-MOUNT ADAPTER KIT PART NUMBER: U2PTRMT

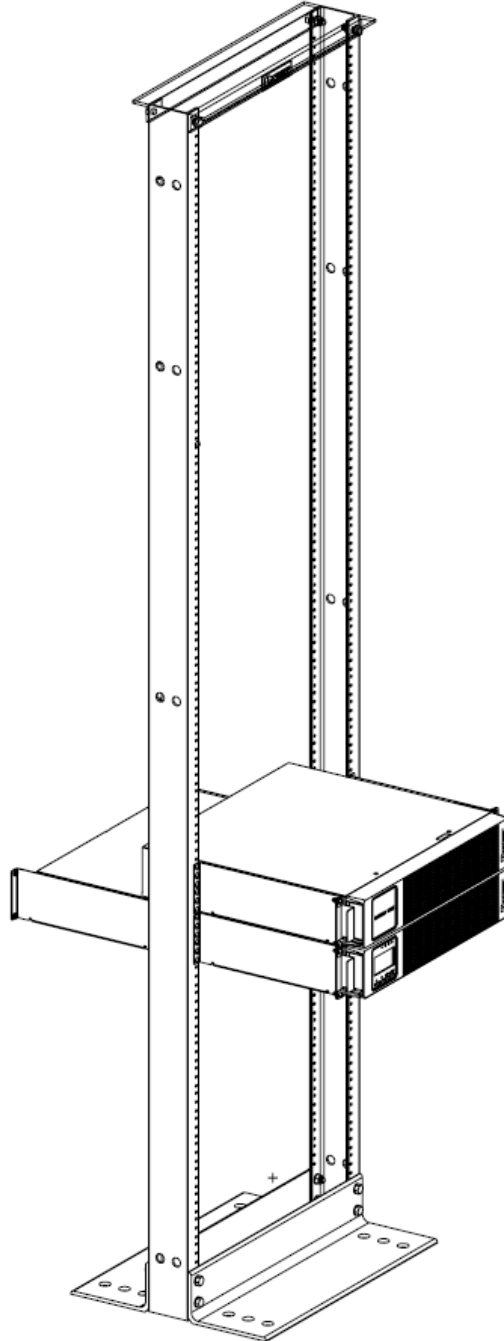

Tools needed:

1. Philips screwdriver
2. Torque wrench

UPS 2-POST RACK-MOUNT ADAPTER KIT U2PTRMT COMPONENTS

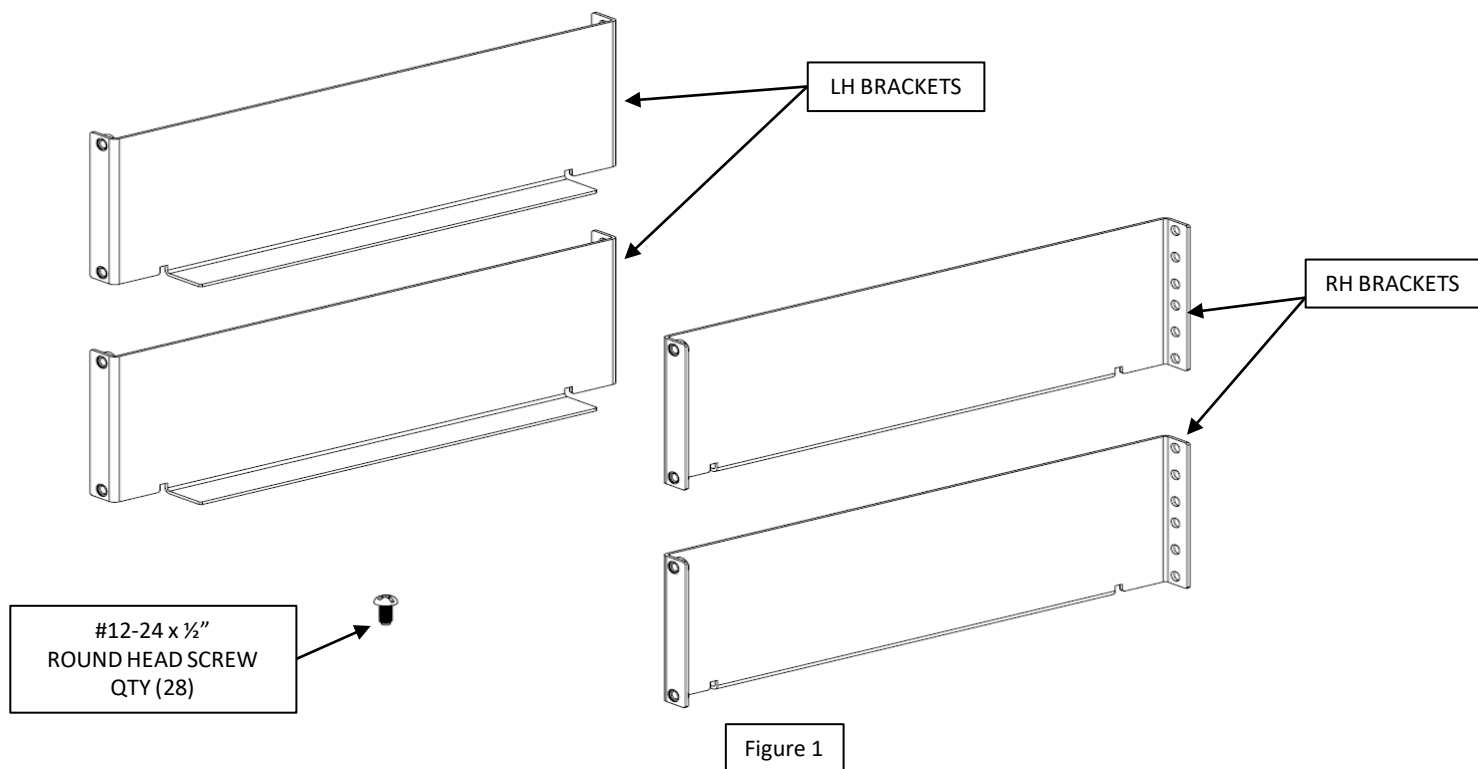

- The 2-Post Rack-Mount Adapter Kit consist (2) LH and brackets, (2) RH brackets and (24) #12-24 x 1/2" round head screws.

UPS 2-POST RACK-MOUNT ADAPTER KIT INSTALLATION – OPTION 1

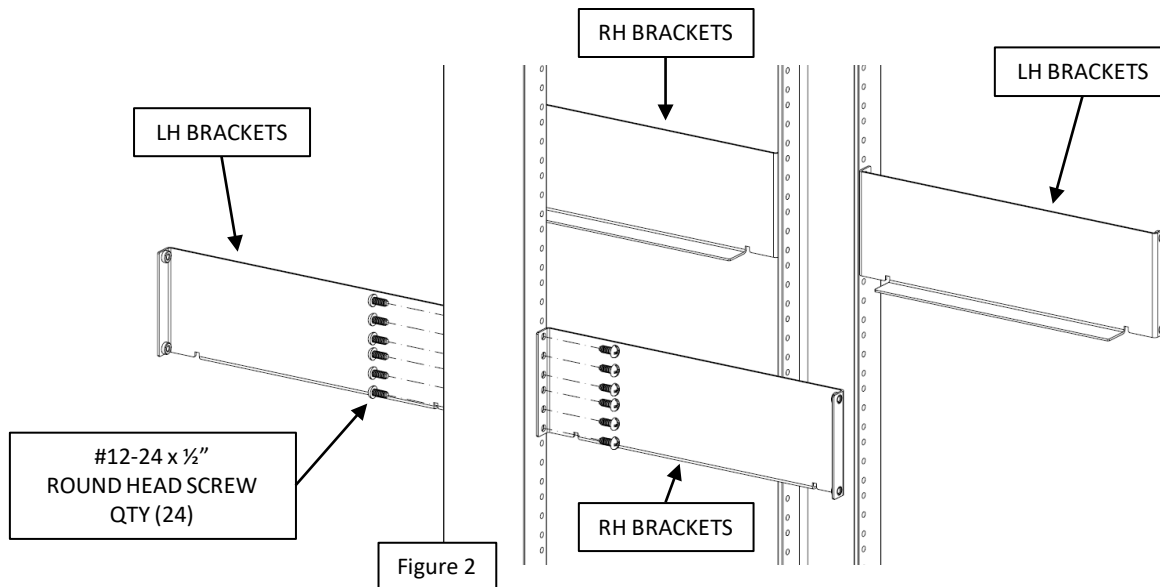

- Position two LH and two RH brackets on 2-Post Rack and secure with (24) #12-24 x 1/2" round head screws (6 screw per each bracket), Figure 2. Use Phillips screwdriver.
- Torque all screws to 5.1Nm (45 in-lbs).

UPS INSTALLATION

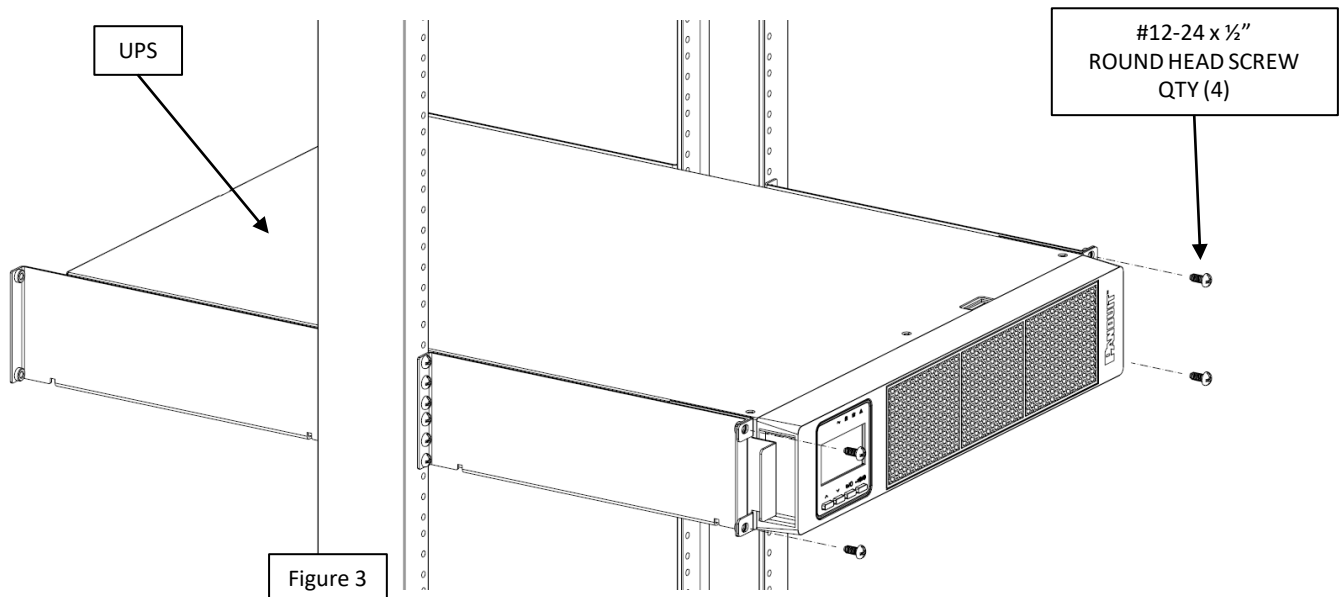

- Place the UPS on previously installed brackets and secure with (4) #12-24 x 1/2" round head screws, Figure 3. Use Phillips screwdriver.
- Torque all screws to 5.1Nm (45 in-lbs).

UPS 2-POST RACK-MOUNT ADAPTER KIT INSTALLATION – OPTION 2

FOR UPS's WHICH TOTAL LENGTH DOES NOT EXTEND MORE THAN 1.09" (104mm) OVER THE REAR FACE OF THE POST, FIGURE 5.

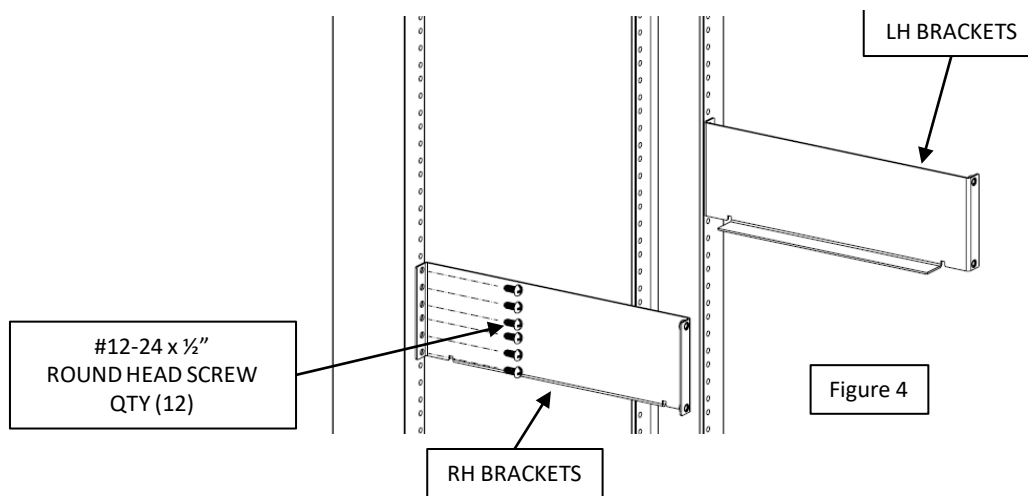

- Position one LH and one RH brackets on 2-Post Rack and secure with (12) #12-24 x 1/2" round head screws (6 screw per each bracket), Figure 4. Use Phillips screwdriver.
- Torque all screws to 5.1Nm (45 in-lbs).

UPS INSTALLATION

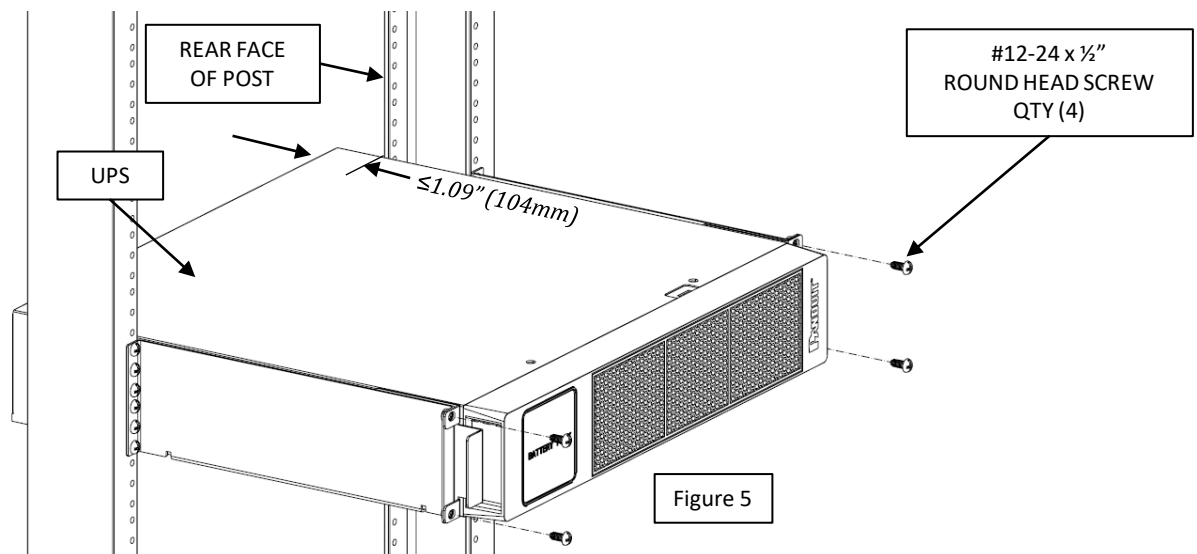

- Place the UPS on previously installed brackets and secure with (4) #12-24 x 1/2" round head screws, Figure 5. Use Phillips screwdriver.
- Torque all screws to 5.1Nm (45 in-lbs).