

THIS COPY IS PROVIDED ON A RESTRICTED BASIS AND IS NOT TO BE USED IN ANY WAY DETRIMENTAL TO THE INTERESTS OF PANDUIT CORP.

NOTES:

- VISIT OUR ON-LINE CATALOG AT WWW.PANDUIT.COM FOR A LIST OF CURRENT PARTS APPLICABLE FOR USE WITH THIS PRODUCT.
- DIMENSIONS ARE METRIC.
- ALL MATERIALS AND COMPONENTS USED MEET THE MATERIAL RESTRICTIONS OF RoHS (EUROPEAN DIRECTIVE 2011/65/EU ON THE RESTRICTION OF HAZARDOUS SUBSTANCES) AS PROPOSED BY THE RoHS TECHNICAL ADAPTATION COMMITTEE.
- NET WEIGHT: 5.5KG
- PROVIDE PART:
 FRE2UBL: FIBER ENCLOSURE 2RU BLACK
 FRE2UWH: FIBER ENCLOSURE 2RU WHITE

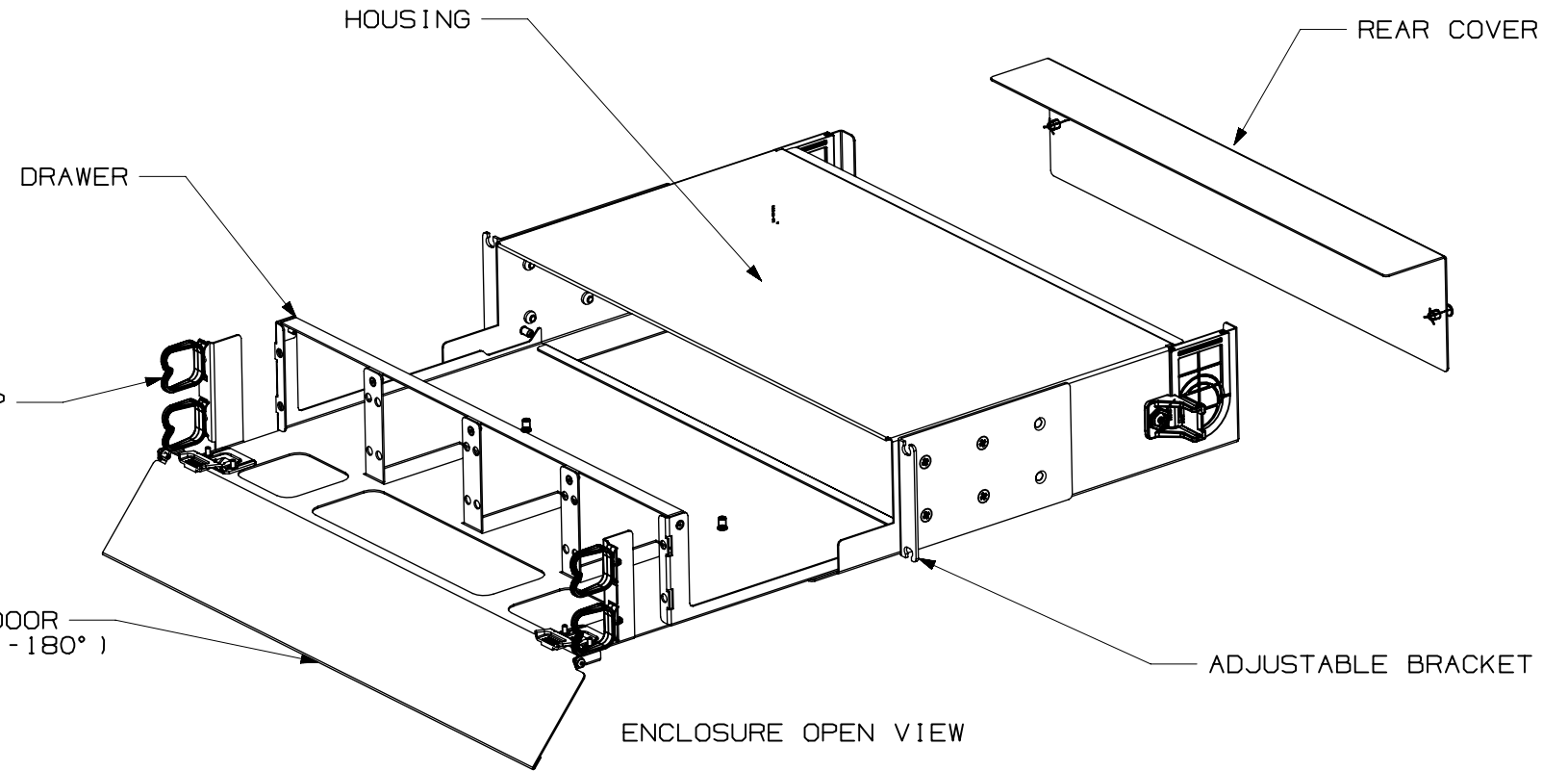
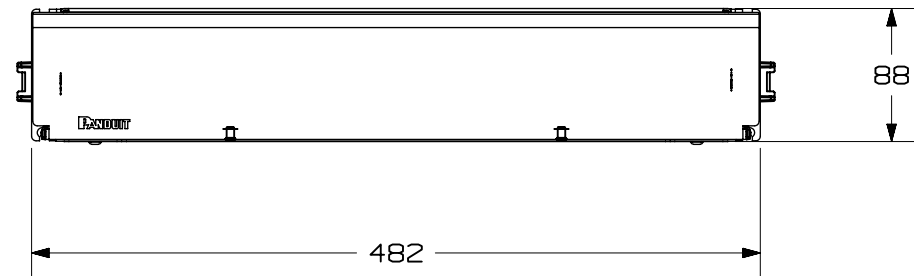
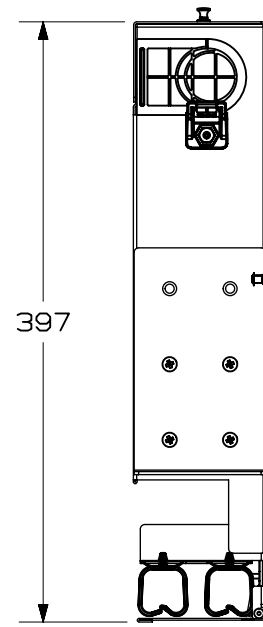
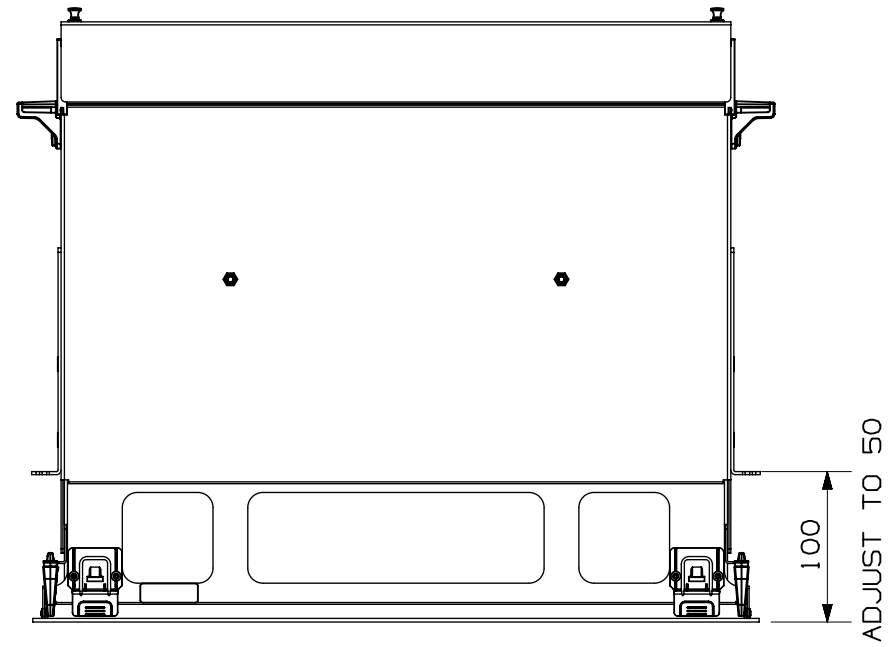

KIT BAG PART LIST

10	M5 FLANGE HEX NUT	2
9	SPIRAL WRAP L=24"	1
8	FIBER CAUTION/DANGER LABEL	1
7	FIBER LASER BEAM WARNING LABEL	1
6	Cable Tie, 7.4L (188mm), Standard, Weather Resistant, Black	4
5	SCREW, (4) #12-24 X .5	1
4	SCREW, (4) M6X1.0-6HX 15MM	1
3	M5x0.8 BUTTON HEAD	2
2	STRAIN RELIEF BRACKET	2
1	Bevel Entry Cord Clip, Adh., .75" (19.1mm) Bundle, BL	1
ITEM	DESCRIPTION	QTY

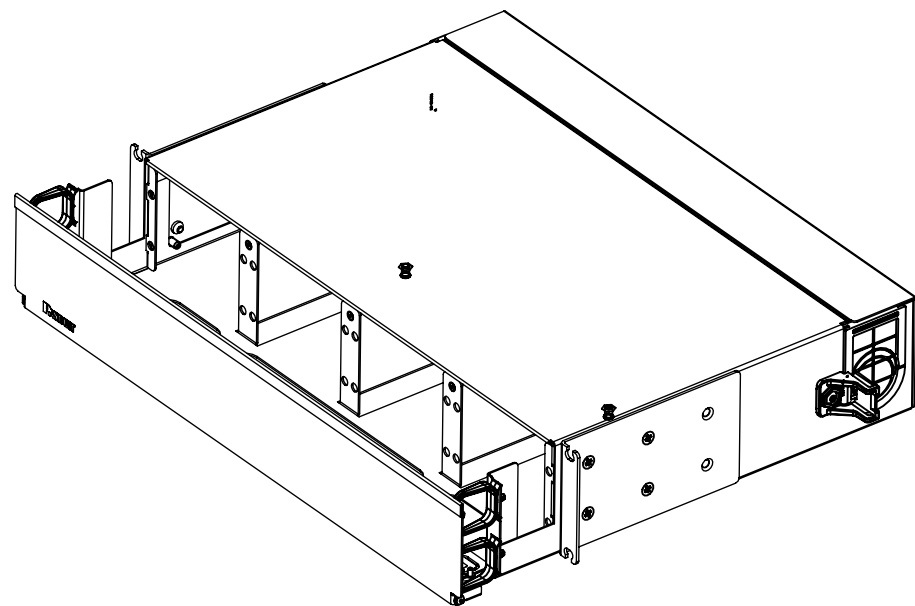

ENCLOSURE CLOSE VIEW

PART NUMBER		SEE NOTE 5	
TITLE		FIBER ENCLOSURE 2RU ASSY FRE2U*	
CUSTOMER DRAWING			
ITEM REVISION NAME		01030EAH/03	
DATASET FILE NAME		01030EAH_DC/03A	
MATERIAL		NA	
DRAWING NUMBER		01030EAH-DC	
DRAWN BY		DATE	CHK
Luke		Aug 21 2023	JSP
SCALE		1:5	
SHEET 1 OF 1		B	

REV	DATE	BY	CHK	APR	DESCRIPTION	ECN
03A	Oct 27 23	Luke	JSP	MZZ	UPDATE THE DRAWER DESIGN	132329-03

B-SIZE CUSTOMER