

THIS COPY IS PROVIDED ON A RESTRICTED BASIS AND IS NOT TO BE USED IN ANY WAY DETRIMENTAL TO THE INTERESTS OF PANDUIT CORP.

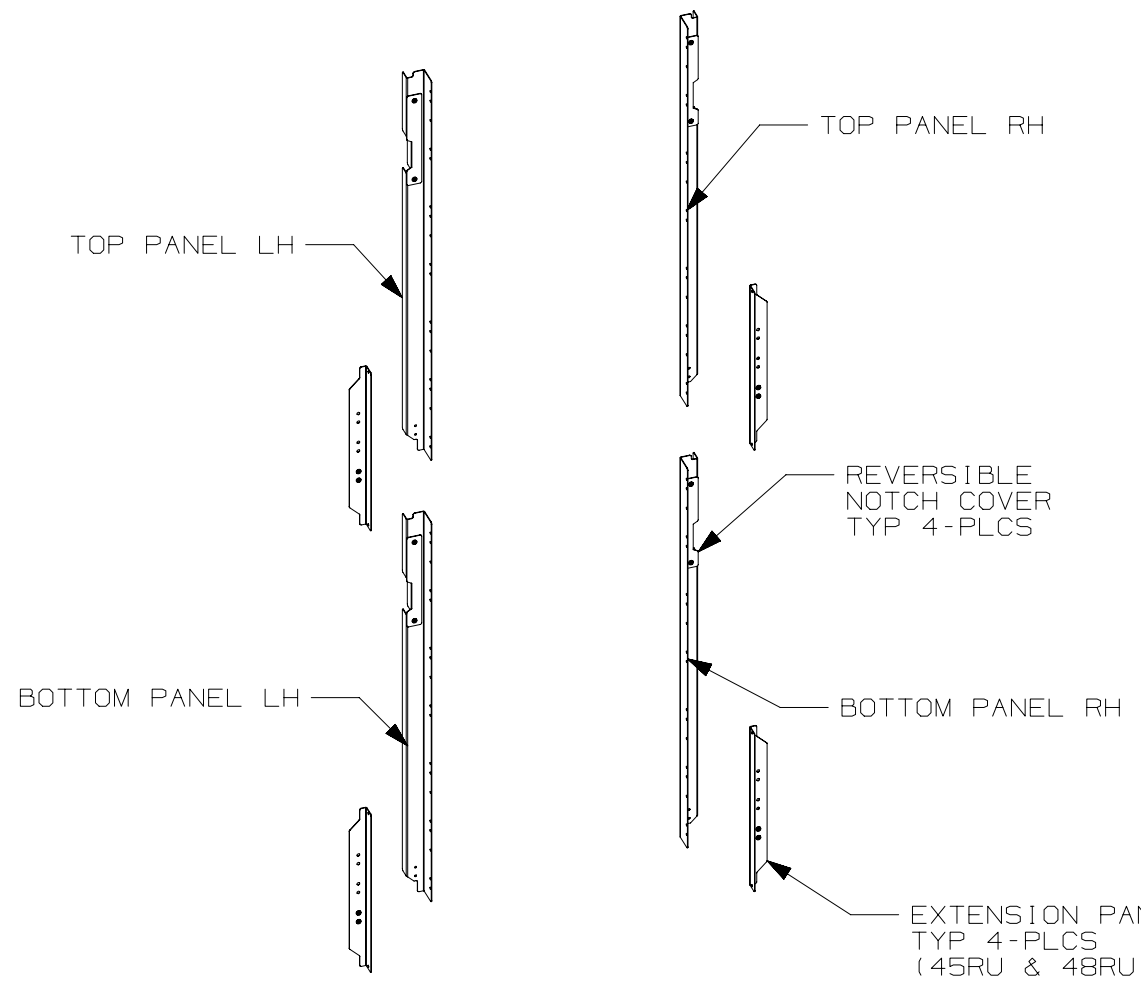

- NOTES:
1. VISIT OUR ONLINE CATALOG AT WWW.PANDUIT.COM FOR A LIST OF CURRENT PARTS APPLICABLE WITH THIS PRODUCT.
 2. REFER TO INSTRUCTION SHEET V00029LB FOR MORE INFORMATION
 3. PARTS SUPPLIED:
 - 2 - TOP PANELS LH & RH
 - 2 - BOTTOM PANELS LH & RH
 - 4 - REVERSIBLE NOTCH COVERS
 - 4 - EXTENSION PANELS
 - 1 - HARDWARE KIT (NOT SHOWN)
 - 1 - INSTALLATION INSTRUCTION (NOT SHOWN).

PANDUIT PART NO.	WEIGHT
D6VBP*	4.5 Kg/EACH (9.92 LBS/EACH)

NOTE:
* DENOTES COLOR - ADD SUFFIX "B" FOR BLACK AND "W" FOR WHITE

B

B

A

A

REV	DATE	BY	CHK	APR	DESCRIPTION	ECN
08A	6/1/18	MEX-JAGC	DWR	SJP	B. ADDED SHEET 3 FOR 48RU APPLICATION VIEW A. GEOMETRY OF EXTENSION PANEL HAS CHANGED	V09001RP/00
07A	1/11/17	MES	DWR	DWR	RELEASED TO PRODUCTION	V09001CM/05

TITLE		D-TYPE 600mm VERTICAL BLANKING PANEL (D6VBP*)	
		CUSTOMER DRAWING	
ITEM REVISION NAME		15V526ZQ/08	
DATASET FILE NAME		15V526ZQ_DC/08A	
MATERIAL:		N/A	
DRAWING NUMBER:		15V526ZQ-DC	
DRAWN BY	DATE	CHK	SCALE
MES	1/11/17	DWR	NONE
THIRD ANGLE PROJECTION		SHT 1 OF 3	
SIZE		A	

THIS COPY IS PROVIDED ON A RESTRICTED BASIS AND IS NOT TO BE USED IN ANY WAY DETRIMENTAL TO THE INTERESTS OF PANDUIT CORP.

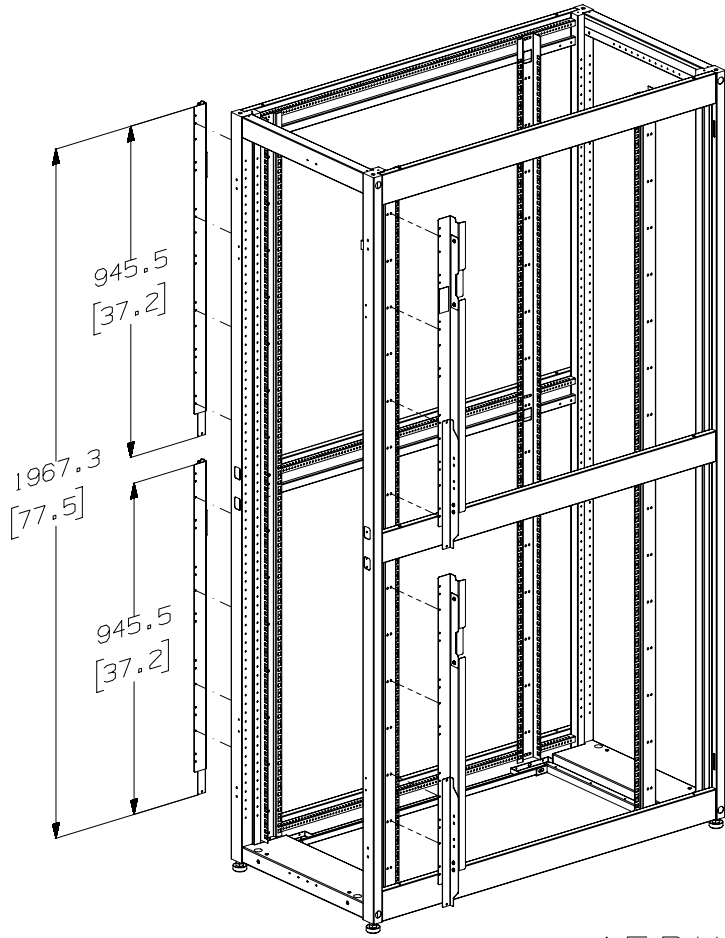

45RU

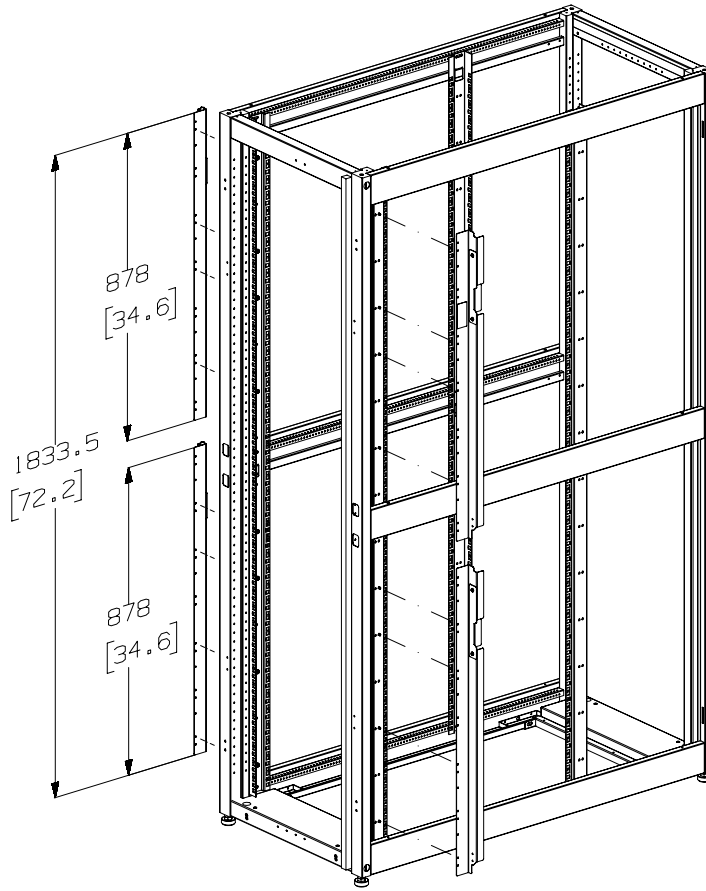

42RU

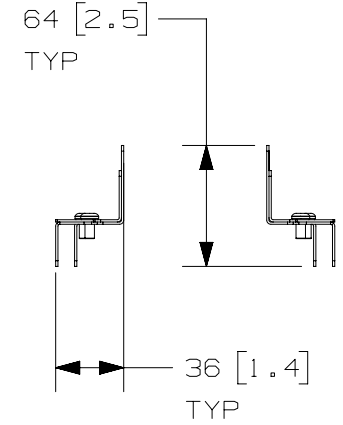

TOP VIEW

REV	DATE	BY	CHK	APR	DESCRIPTION	ECN
08A	6/1/18	MEX-JAGC	DWR	SJP	SEE SHEET 1 FOR REVISIONS	V09001RP/00
07A	1/12/17	MES	DWR	DWR	RELEASED TO PRODUCTION	V09001CM/05

TITLE		D-TYPE 600mm VERTICAL BLANKING PANEL (D6VBP*)	
		CUSTOMER DRAWING	
ITEM REVISION NAME		15V526ZQ/08	
DATASET FILE NAME		15V526ZQ_DC/08A	
MATERIAL:		N/A	
DRAWING NUMBER:		15V526ZQ-DC	
DRAWN BY	DATE	CHK	SCALE
MES	1/12/17	DWR	NONE
SHT 2 OF 3		A	

2

1

THIS COPY IS PROVIDED ON A RESTRICTED BASIS AND IS NOT TO BE USED IN ANY WAY DETRIMENTAL TO THE INTERESTS OF PANDUIT CORP.

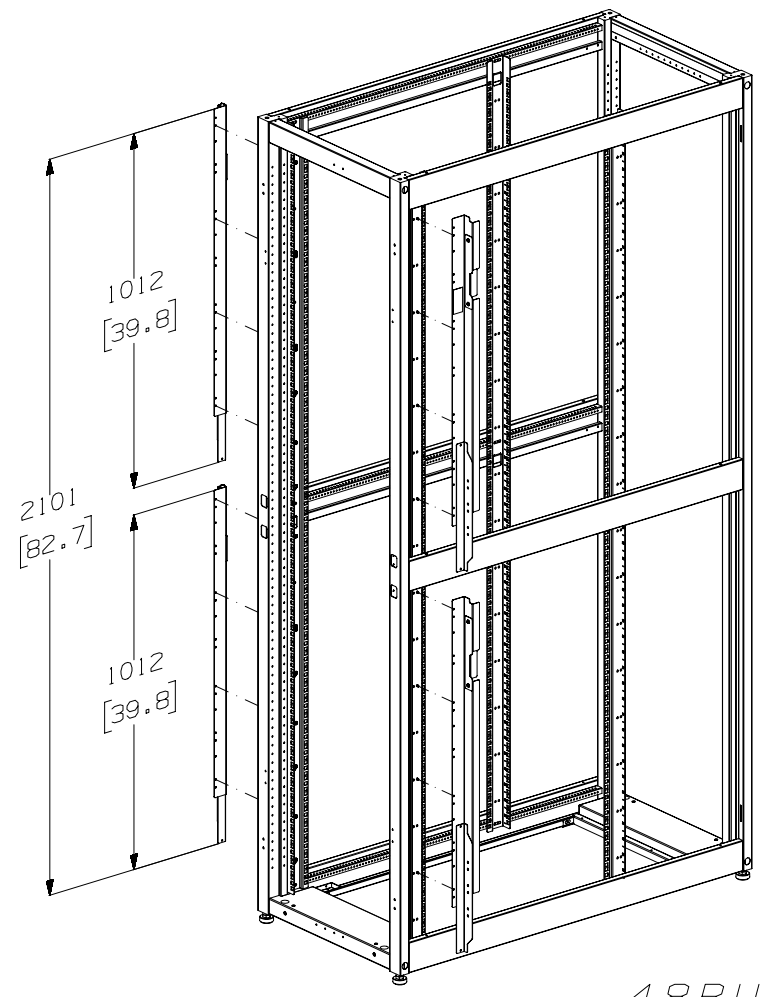

48RU

08A	6/1/18	MEX-JAGC	DWR	SJP	SEE SHEET 1 FOR REVISIONS	V09001RP/00
07A	1/12/17	MES	DWR	DWR	RELEASED TO PRODUCTION	V09001CM/05
REV	DATE	BY	CHK	APR	DESCRIPTION	ECN

TITLE		D-TYPE 600mm VERTICAL BLANKING PANEL (D6VBP*)	
		CUSTOMER DRAWING	
ITEM REVISION NAME		15V526ZQ/08	
DATASET FILE NAME		15V526ZQ_DC/08A	
MATERIAL:		N/A	
DRAWING NUMBER:		15V526ZQ-DC	
DRAWN BY		DATE	CHK
MES	1/12/17	DWR	SCALE
		NONE	
SHT 3 OF 3		SIZE	
		A	

2

1