

THIS COPY IS PROVIDED ON A RESTRICTED BASIS AND IS NOT TO BE USED IN ANY WAY DETRIMENTAL TO THE INTERESTS OF PANDUIT CORP.

NOTES, UNLESS OTHERWISE SPECIFIED:

1. DIMENSIONS IN BRACKETS ARE IN METRIC. (A)
2. RECOMMENDED TOOL: CT-3001/ST SERIES
3. COMPATIBLE TOOLS: CT-3001/CCP SERIES, CT-930LPCH
4. WIRE SIZE: 400kcmil
5. CRIMPS: F94 FERRULES - ALL SIZES
6. DIE HALVES ARE HEAT TREATED TO Rc 32-35
7. DIE HALVES ARE NICKLON PLATED FOR LUBRICITY/DURABILITY
8. DIE HALVES AND PLATING ARE RoHS COMPLIANT (A)

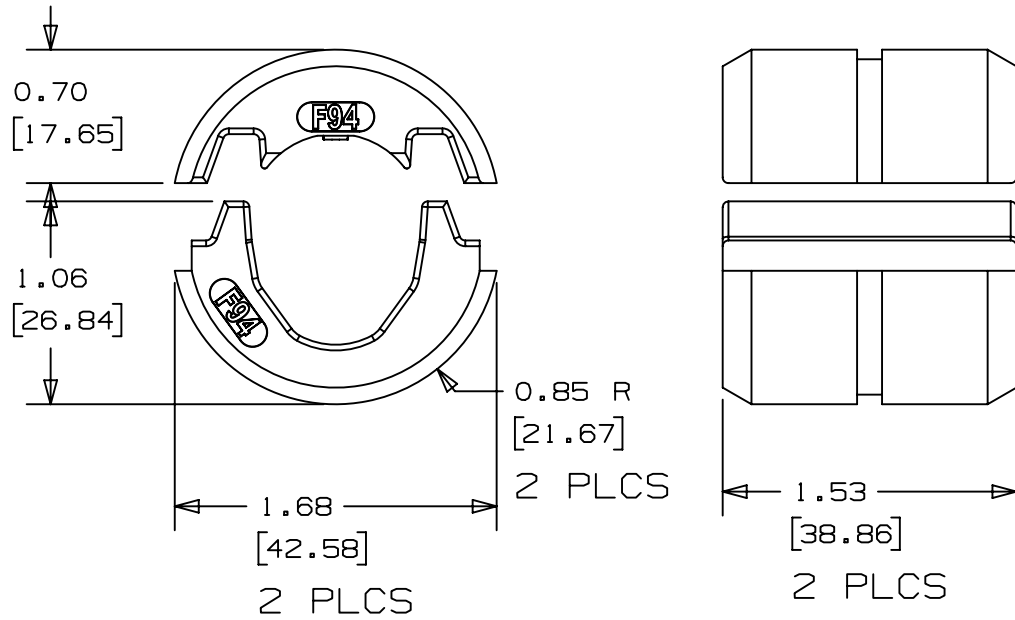

INSTALLATION INSTRUCTION NUMBER PA28870A01		FMEA & CONTROL PLAN NUMBER N/A					
TITLE CD-920-F94 CUSTOMER DRAWING							
CUSTOMER DRAWING							
ITEM REVISION NAME R28880AA/01		<b>PANDUIT</b>					
DATASET FILE NAME R28880AA_DS_TD28880A01/01							
UNLESS OTHERWISE SPECIFIED, DIMENSIONAL TOLERANCES ARE: IN [mm]		MATERIAL: 4140 STEEL / RC 32-35					
.x ± .1 [ 2.54 ]      .xxx ± .005 [ .127 ] .xx ± .01 [ .25 ]      ANGLES ± 5 °		DRAWING NUMBER: TD28880A01					
THIRD ANGLE PROJECTION		SHT 1 OF 1					
DRAWN BY BJPU	DATE 03/30/17	CHK JADE	SCALE 1:1				
REV	DATE	BY	CHK	APR	DESCRIPTION	ECN	SIZE A

01	11-2-17	BJPU	JEH	JADE	REMOVED CT-2931/ST AND CT-920CH TOOLS, ADDED CT-3001/CCP TOOL, ADDED NOTE #8 (A)	017591
00	03-30-17	BJPU	JEH	JADE	RELEASED	012679