

THIS COPY IS PROVIDED ON A RESTRICTED BASIS AND IS NOT TO BE USED IN ANY WAY DETRIMENTAL TO THE INTERESTS OF PANDUIT CORP.

TABLE 1 - COMPONENTS IN EACH BOX

ITEM NO.	DESCRIPTION	QTY.
1	CONNECTOR STUB HOLDER	1
2	FERRULE SUBASSEMBLY (IN BLISTER PACK)	10
3	FRONT HOUSING	10
4	SPRING	10
5	BOOT ASSEMBLY	10
6	SPLICE PROTECTION SLEEVE	10

NOTES:

- VISIT OUR ON-LINE CATALOG AT WWW.PANDUIT.COM FOR A LIST OF CURRENT PARTS APPLICABLE FOR USE WITH THIS PRODUCT.
- EACH BAG CONTAINS:
 - TEN (10) CONNECTORS
 - ONE (1) CONNECTOR STUB HOLDER
 - INSTALLATION INSTRUCTIONS
- WEIGHT OF BOX: 2.6 oz (0.16 lbs)
- TIA/EIA-604 FOCIS-10 COMPATIBLE.
- MEETS OR EXCEEDS TIA/EIA-568-D.3 PERFORMANCE REQUIREMENTS.
- COMPATIBLE WITH SUMITOMO FUSION SPLICERS.

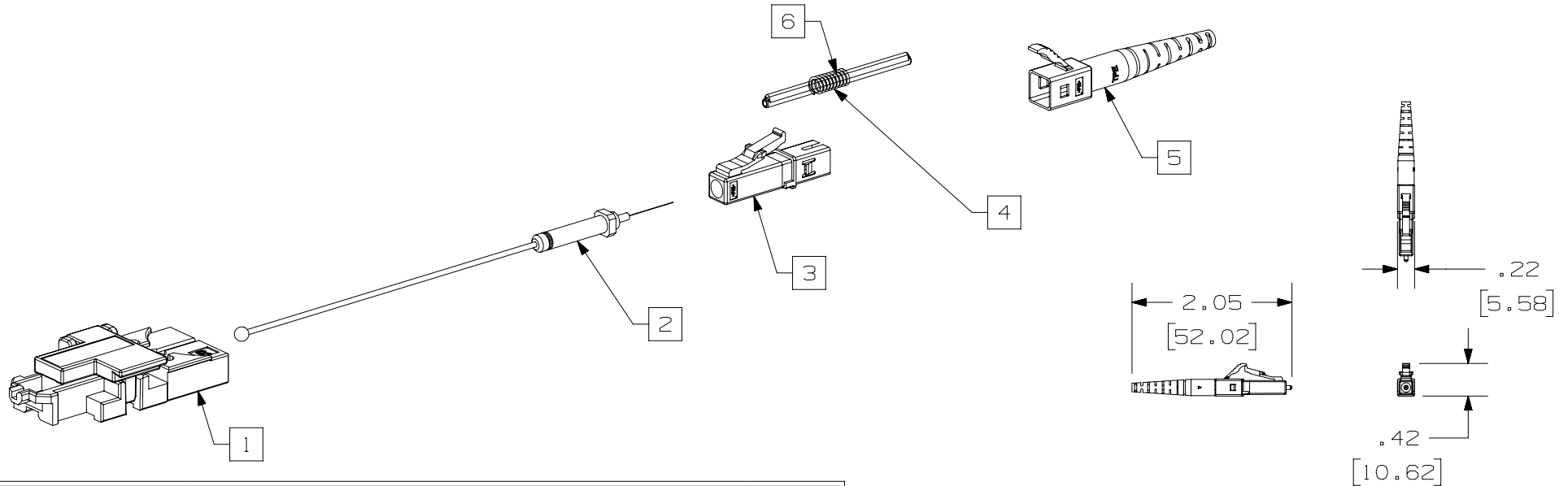
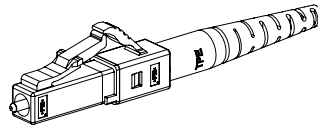

TABLE 2 - PART NUMBERS

PART NUMBER	DESCRIPTION	BOOT COLOR
FLCSLT9S0CU9BU	Fiber LC-UPC Splice-On Connector for 250um Fiber with Build-up Tubing 9um Singlemode	BLUE
FLCSLT9S0CA9AG	Fiber LC-APC Splice-On Connector for 250um Fiber with Build-up Tubing 9um Singlemode	GREEN
FLCSLT9S0CPXAQ	Fiber LC-PC Splice-On Connector for 250um Fiber with Build-up Tubing 50um Multimode	AQUA

PART NUMBER		SEE TABLE 2	
TITLE			
LC FUSION SPLICE CONNECTOR FOR 250um W/ 900um BUILDUP TUBE		CUSTOMER DRAWING	
ITEM REVISION NAME		01199EAA/00	
DATASET FILE NAME		01199EAA_DC/00A	
MATERIAL		MULTIPLE	
DRAWING NUMBER		01199EAA-DC	
DRAWN BY		BJN	
DATE		7-19-22	
CHK		BSN	
SCALE		NONE	
SHEET 1 OF 1		A	

REV	DATE	BY	CHK	APR	DESCRIPTION	ECN
00A	7-19-22	BJN	BSN	SKH	INITIAL RELEASE	01199EAA-DC

A-SIZE CUSTOMER