

THIS COPY IS PROVIDED ON A RESTRICTED BASIS AND IS NOT TO BE USED IN ANY WAY DETRIMENTAL TO THE INTERESTS OF PANDUIT CORP.

NOTES:

1. SPLICE CASSETTE IS COMPATIBLE WITH OPTI-COM PANELS AND ENCLOSURES. VISIT [WWW.PANDUIT.COM](http://WWW.PANDUIT.COM) FOR ADDITIONAL INFORMATION.
2. DIMENSIONS IN [ ] ARE METRIC.
3. ALL MATERIALS AND COMPONENTS USED MEET THE MATERIAL RESTRICTIONS OF RoHS (EUROPEAN DIRECTIVE 2011/65/EU ON THE RESTRICTION OF HAZARDOUS SUBSTANCES) AS PROPOSED BY THE RoHS TECHNICAL ADAPTATION COMMITTEE.
4. PART INCLUDES:
  - 1- BASE
  - 1- COVER
  - 6- SC ADAPTERS
  - 12- 1 METER PIGTAIL
  - 1- PERFORMANCE LABEL
  - 1- SPLICE HOLDER WITH TAPE
  - 3- COVER MOUNTING SCREW
  - 4- PLT1.5I-M CABLE TIE
  - 4- 1" SECTION OF GROMMET EDGING
  - 12- SPLICE PROTECTOR

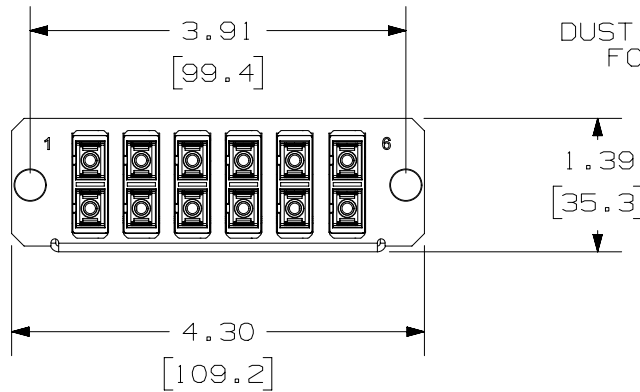
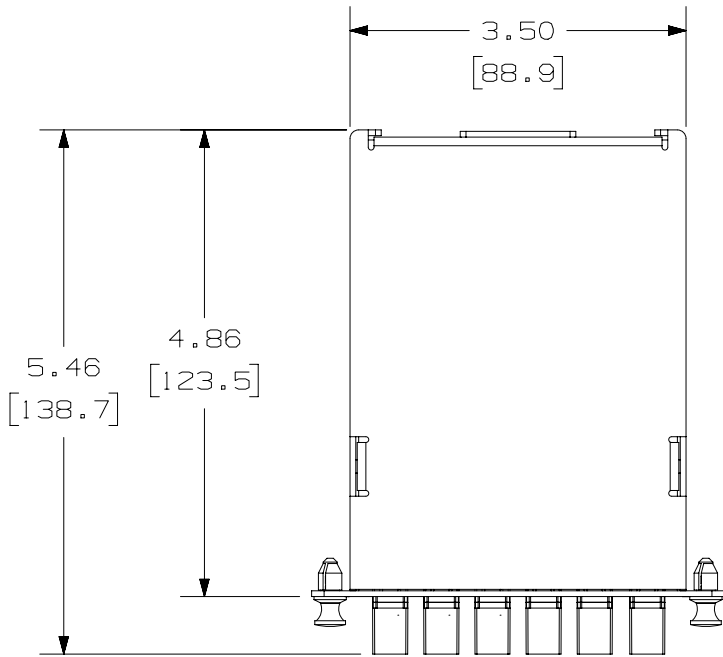

DUST CAPS REMOVED FOR CLARITY.

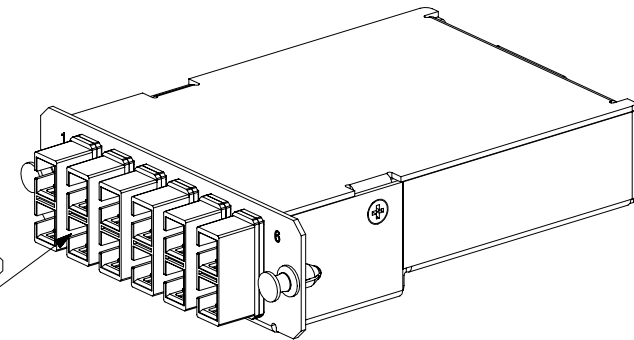

PART NUMBER		SEE TABLE, SHEET 2		
TITLE				
OPTI-COM SPLICE CASSETTE, 6 DUPLEX SC				
CUSTOMER DRAWING				
ITEM REVISION NAME		10F113JF/01		
DATASET FILE NAME		10F113JF_DC/01A		
MATERIAL		BLACK POWDER COATED ALUMINUM		
DRAWING NUMBER		10F113JF-DC		
DRAWN BY		DATE	CHK	SCALE
JSP		2/5/20	WJM	NONE
REV		DATE	BY	CHK
01A		2/5/20	JSP	WJM
APR		EJH		
DESCRIPTION		INITIAL RELEASE		
ECN		10F113JF-DC		
SHEET 1 OF 2		A		

A-SIZE CUSTOMER

2

1

2

1

2

1

THIS COPY IS PROVIDED ON A RESTRICTED BASIS AND IS NOT TO BE USED IN ANY WAY DETRIMENTAL TO THE INTERESTS OF PANDUIT CORP.

PART NUMBER	DESCRIPTION
FCS9N-12-03P	OPTI-COM OS2 SPLICE CASSETTE, DUPLEX SC, PRELOADED WITH 12 PIGTAILS
FCS9N-12-SAP	OPTI-COM OS2 SPLICE CASSETTE, DUPLEX SC/APC, PRELOADED WITH 12 PIGTAILS
FCSZO-12-03P	OPTI-COM OM4 SPLICE CASSETTE, DUPLEX SC, PRELOADED WITH 12 PIGTAILS



B

B

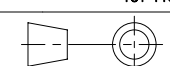

A

A

PART NUMBER		SEE TABLE	
TITLE		OPTI-COM SPLICE CASSETTE, 6 DUPLEX SC	
		CUSTOMER DRAWING	
ITEM REVISION NAME		10F113JF/01	
DATASET FILE NAME		10F113JF_DC/01A	
		THIRD ANGLE PROJECTION	
MATERIAL		BLACK POWDER COATED ALUMINUM	
			
		DRAWING NUMBER	
		10F113JF-DC	
DRAWN BY	DATE	CHK	SCALE
JSP	2/5/20	WJM	NONE
REV		DATE	
BY		CHK	
APR		DESCRIPTION	
ECN		SHEET 2 OF 2	
		A	

A-SIZE CUSTOMER

					SEE SHEET 1				
REV	DATE	BY	CHK	APR	DESCRIPTION	ECN			

2

1