

THIS COPY IS PROVIDED ON A RESTRICTED BASIS AND IS NOT TO BE USED IN ANY WAY DETRIMENTAL TO THE INTERESTS OF PANDUIT CORP.

T-70 RACEWAY KNOCK-OUT
 COMBINATION 1/2" OR 3/4" KNOCK-OUT
 COMBINATION 1" OR 1 1/4" KNOCK-OUT

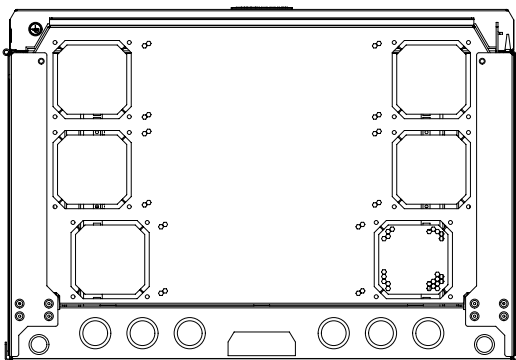

- NOTES:
- VISIT OUR ON-LINE CATALOG AT WWW.PANDUIT.COM FOR A LIST OF CURRENT PARTS APPLICABLE FOR USE WITH THIS PRODUCT.
 - DIMENSIONS IN [] ARE METRIC.
 - CAN BE USED WITH ANY 19" EIA STANDARD COMPONENT UP TO 36.9" [938mm] DEEP.
 - 9 AVAILABLE RACK SPACES. (9 ACTIVE &/OR 9 PASSIVE)
 - EQUIPMENT MOUNTING BRACKETS ARE ADJUSTABLE VERTICALLY IN 1.75" [44.5mm] INCREMENTS.
 - WEIGHT: 112 LB [50.8 KG]
 - LOAD CAPACITY: 400 LBS [181 KG]
 - TOP AND BOTTOM PANELS ARE REMOVABLE FOR ACCESS TO EQUIPMENT.
 - PART INCLUDES:
 - (1) VERTICAL WALL MOUNT ENCLOSURE
 - (1) PAIR OF HORIZONTAL ACTIVE EQUIPMENT RAILS (9RU)
 - (1) PAIR OF ANGLED PASSIVE EQUIPMENT RAILS (9RU)
 - (4) #12-24 SCREWS
 - (4) M5 THREAD FORMING BONDING SCREWS
 - (1) ROLL OF TAK-TY HOOK AND LOOP CABLE TIE
 - (2) KEYS
 - (1) ROLL OF GROMMET EDGING
 - (1) HARDWARE KIT
 - (1) DOOR GUIDE RAMP

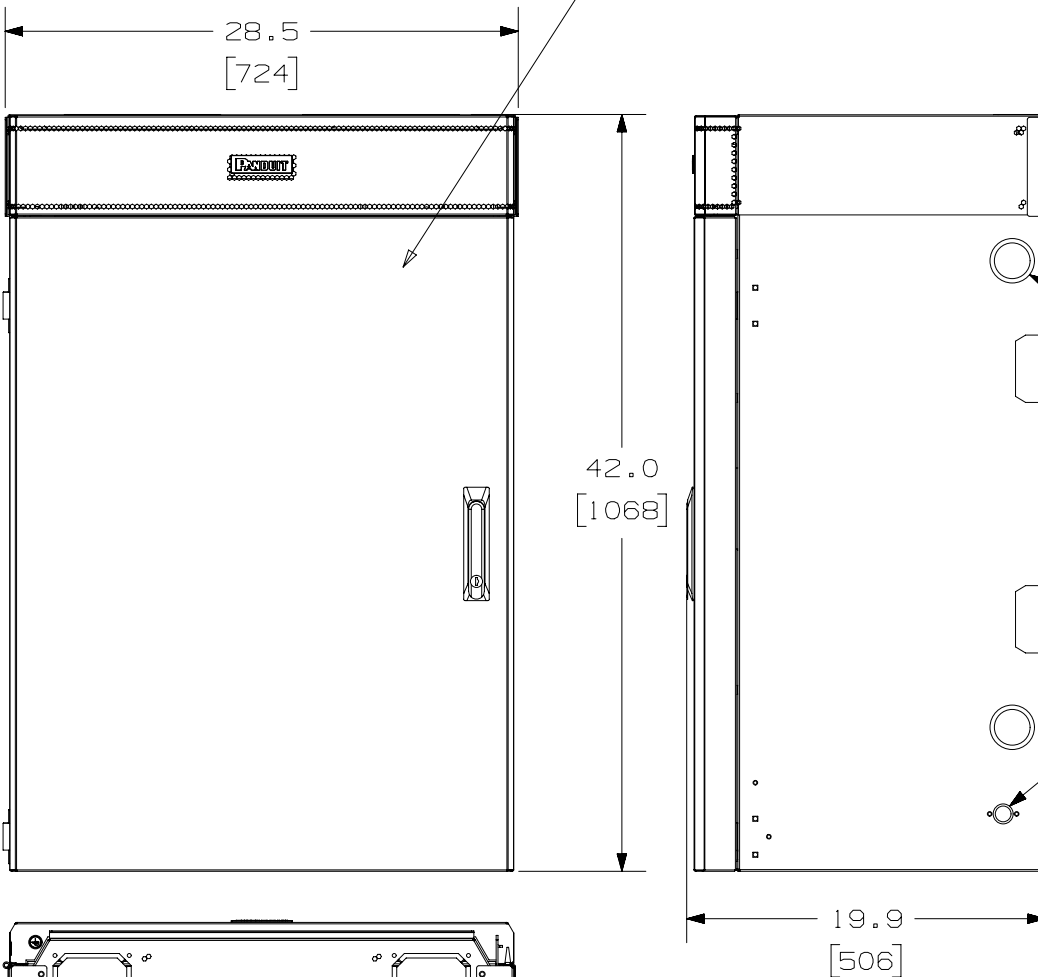
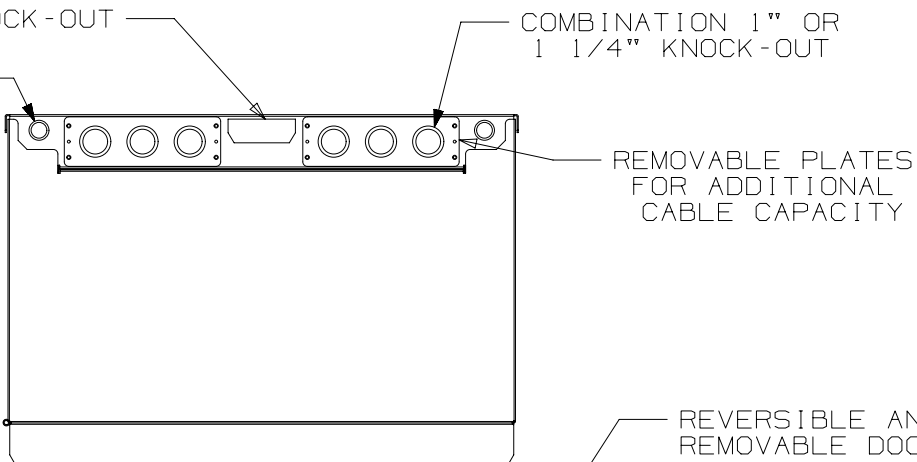
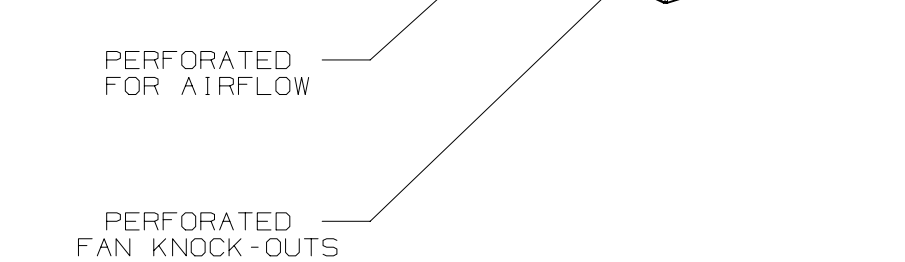
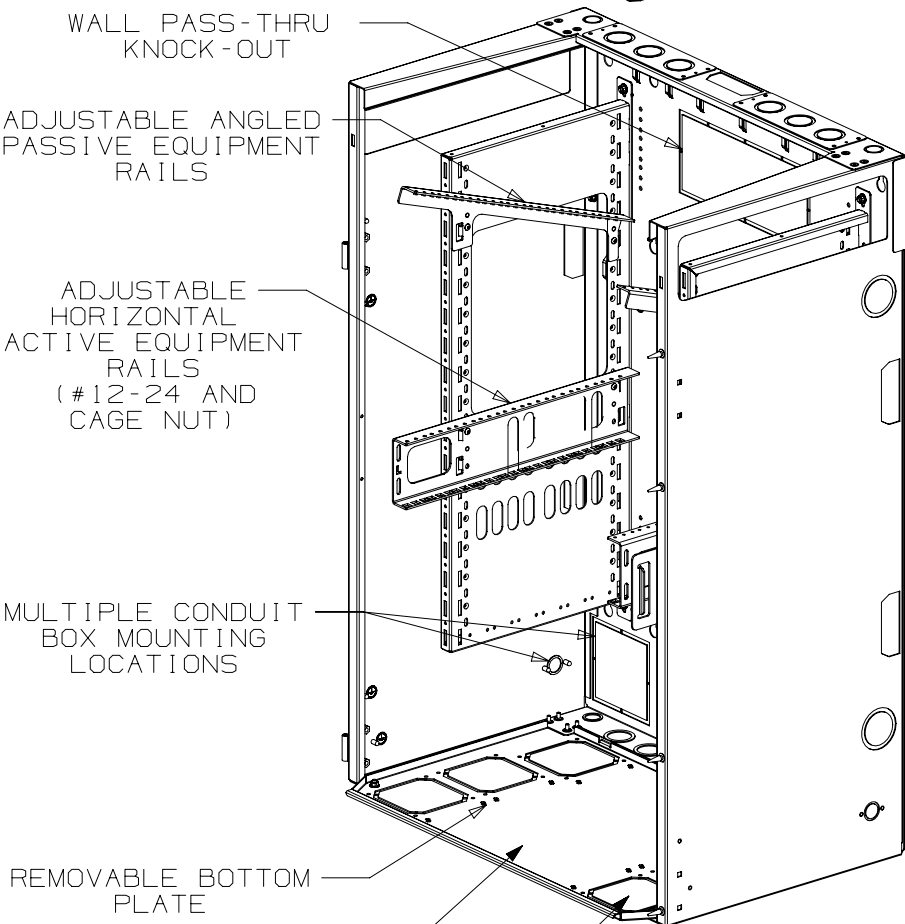
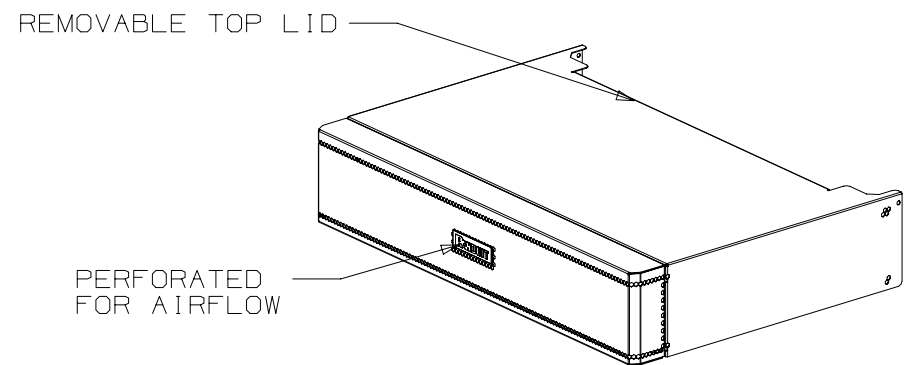
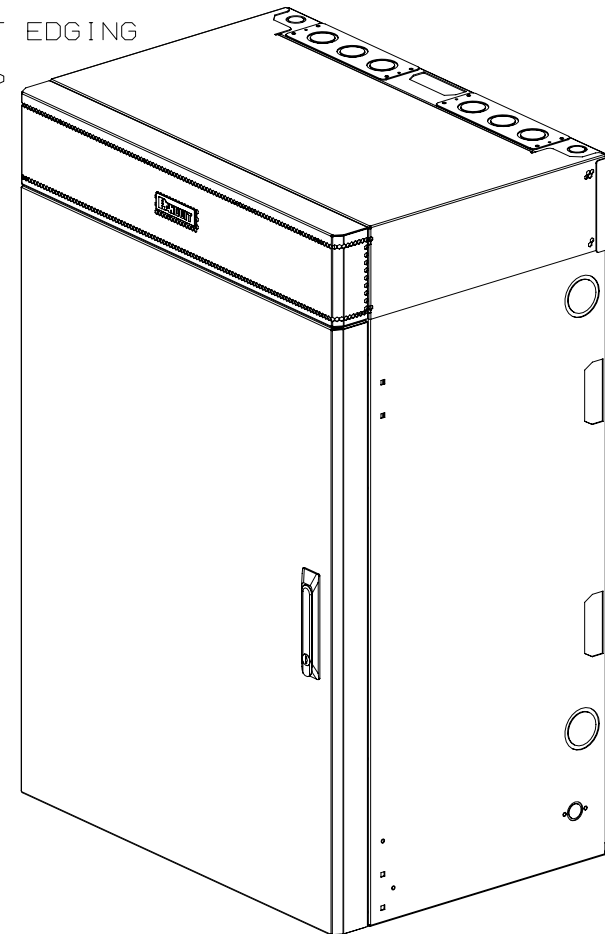

PART NUMBER		WME9BL, WME9WH	
TITLE		VERTICAL WALL MOUNT ENCLOSURE 9RU	
ITEM REVISION NAME		CUSTOMER DRAWING	
DATASET FILE NAME		00490EAC/06	
MATERIAL		STEEL	
DRAWING NUMBER		00490EAC-DC	
DRAWN BY		TJV	
DATE		3-17-20	
CHK		KZU	
SCALE		NONE	
SHEET 1 OF 3		B	

REV	DATE	BY	CHK	APR	DESCRIPTION	ECN
06A	1-23-24	TWV	KZU	BETL	ADDED P/N WME9WH	M09000LL/08
05A	8-31-23	TWV	MPOL	BETL	UPDATED MODEL	M09000LL/07

B-SIZE CUSTOMER

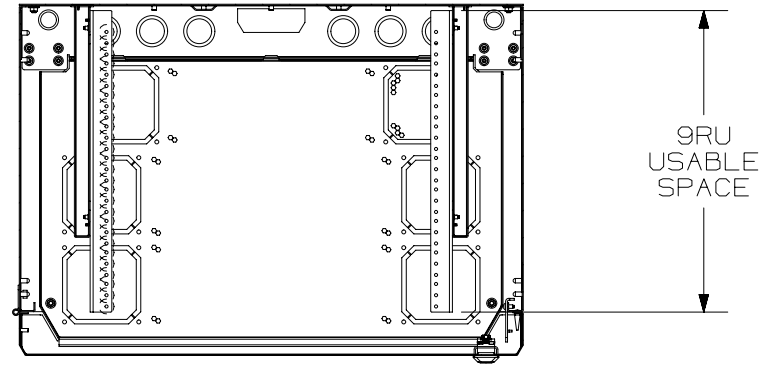

SECTION A - A

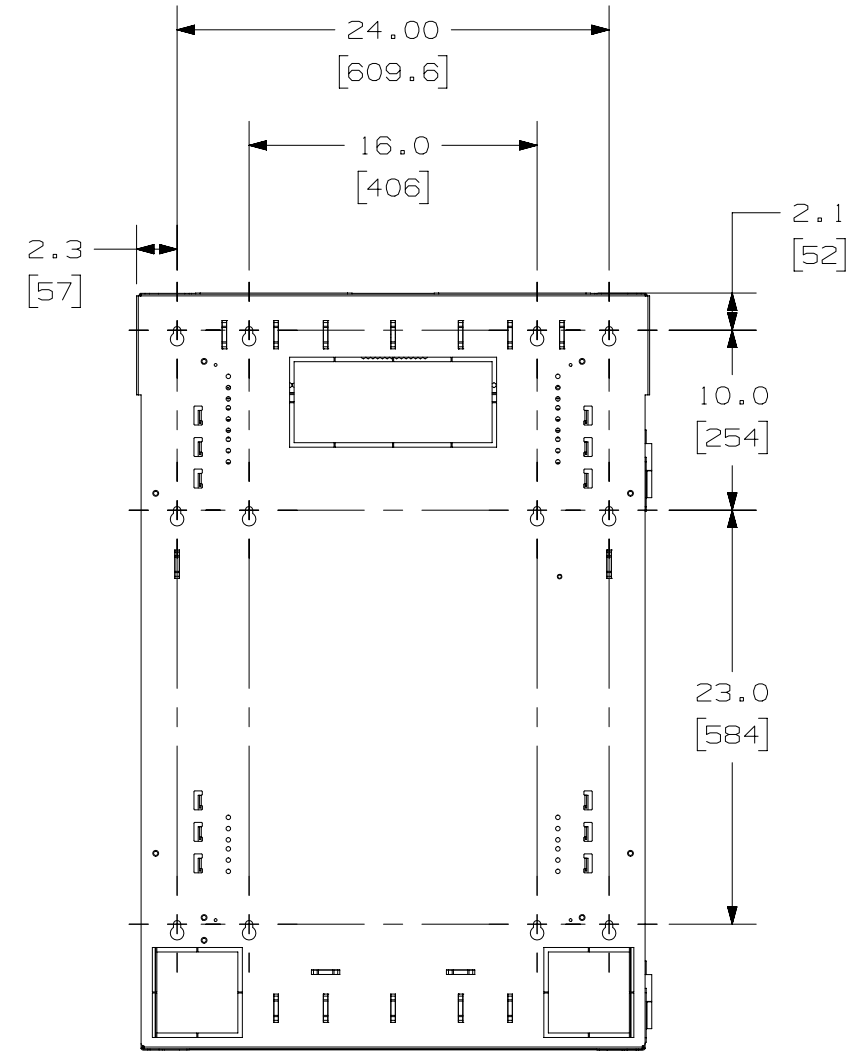
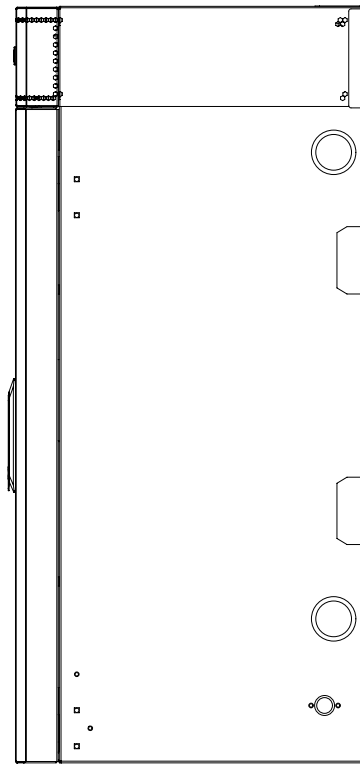
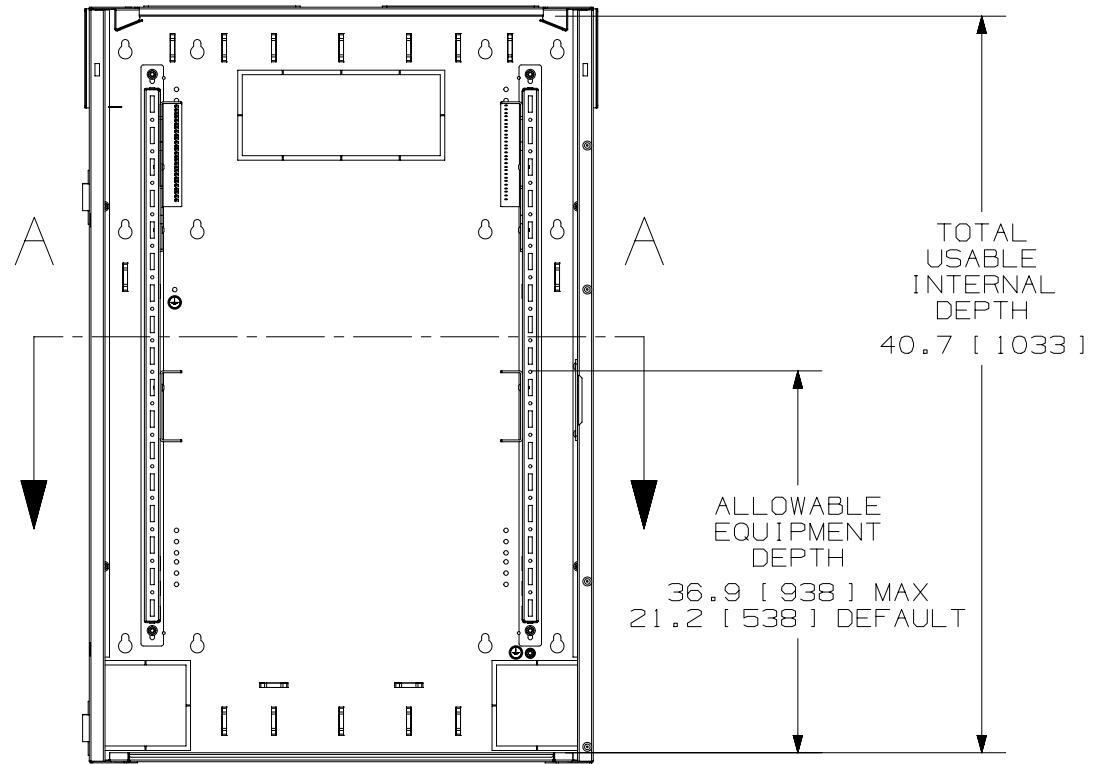

PART NUMBER		WME9BL, WME9WH		
TITLE		VERTICAL WALL MOUNT ENCLOSURE 9RU		
		CUSTOMER DRAWING		
ITEM REVISION NAME		00490EAC/06		
DATASET FILE NAME		00490EAC_DC/06A		
MATERIAL		STEEL		
DRAWING NUMBER		00490EAC - DC		
DRAWN BY		DATE	CHK	SCALE
TWV		3-17-20	KZU	NONE
SHEET 2 OF 3		SIZE B		

REV	DATE	BY	CHK	APR	DESCRIPTION	ECN
06A	1-23-24	TWV	KZU	BETL	SEE SHEET ONE FOR REVISIONS	M09000LL/08
05A	8-31-23	TWV	MPOL	BETL	SEE SHEET ONE FOR REVISIONS	M09000LL/07

B-SIZE CUSTOMER

2



1

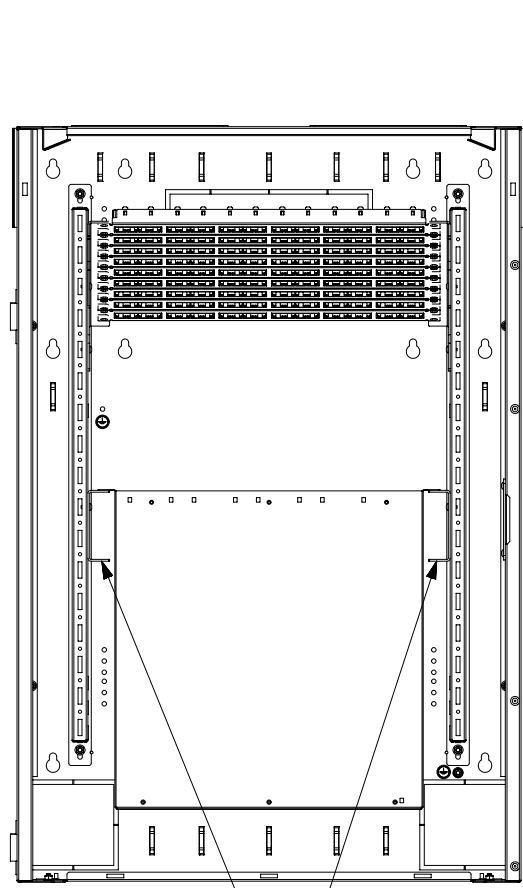

ADJUSTABLE EQUIPMENT BRACKETS (ADJUSTABLE VERTICALLY IN 1.75" [44.5mm] INCREMENTS)

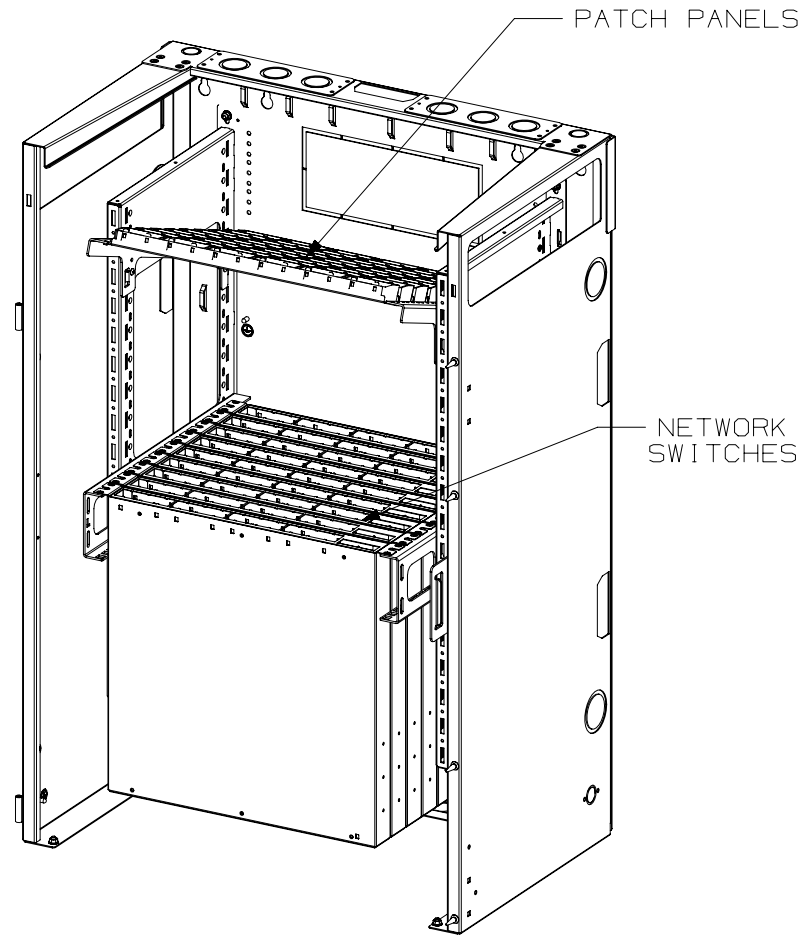

SWITCH CONFIGURATION

PATCH PANELS

NETWORK SWITCHES

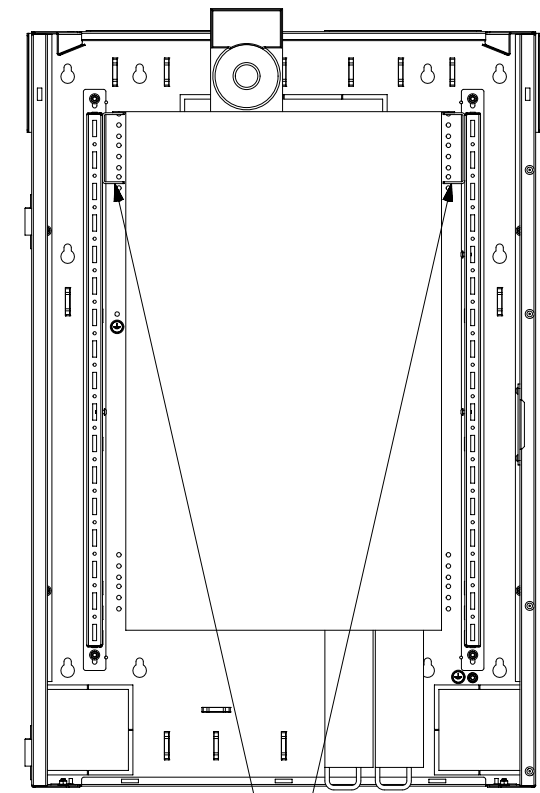

ADJUSTABLE EQUIPMENT BRACKETS (ADJUSTABLE VERTICALLY IN 1.75" [44.5mm] INCREMENTS)

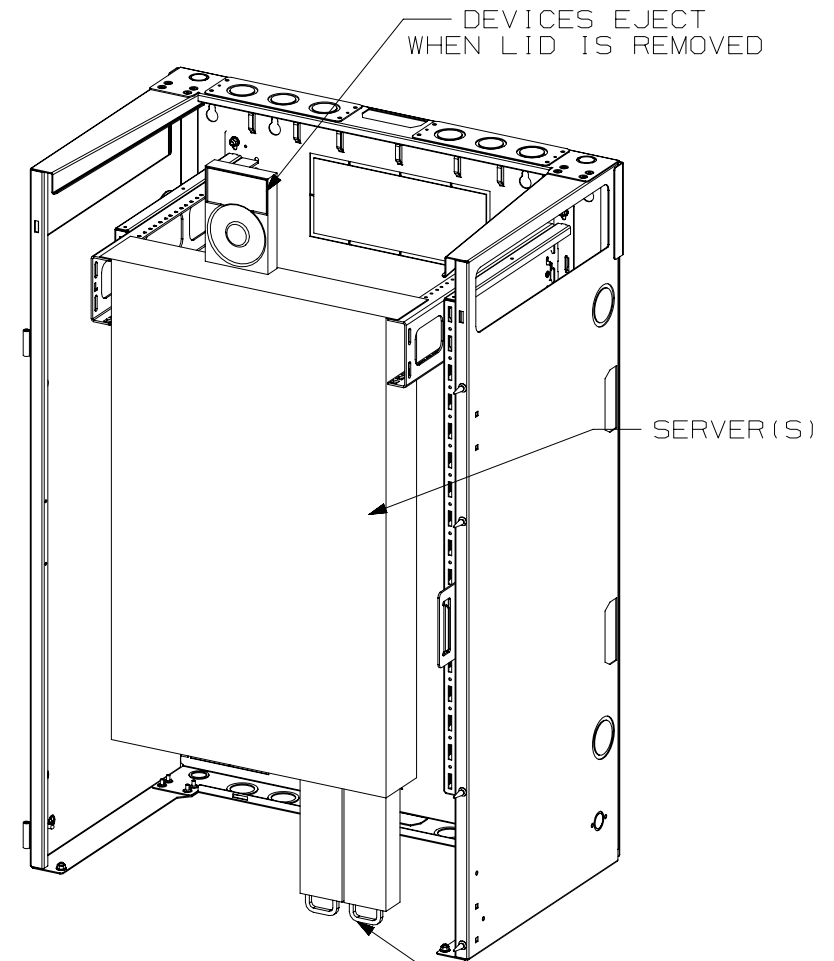

SERVER CONFIGURATION

DEVICES EJECT WHEN LID IS REMOVED

SERVER(S)

DEVICES EJECT WHEN PLATE IS REMOVED

PART NUMBER		WME9BL, WME9WH	
TITLE		VERTICAL WALL MOUNT ENCLOSURE 9RU	
ITEM REVISION NAME		CUSTOMER DRAWING	
DATASET FILE NAME		00490EAC/06	
		00490EAC_DC/06A	
THIRD ANGLE PROJECTION			
MATERIAL		STEEL	
DRAWING NUMBER		00490EAC - DC	
DRAWN BY	DATE	CHK	SCALE
TWV	3-17-20	KZU	NONE
SHEET 3 OF 3			SIZE B

REV	DATE	BY	CHK	APR	DESCRIPTION	ECN
06A	1-23-24	TWV	KZU	BETL	SEE SHEET ONE FOR REVISIONS	M09000LL/08
05A	8-31-23	TWV	MPOL	BETL	SEE SHEET ONE FOR REVISIONS	M09000LL/07

B

B

A

A

B-SIZE CUSTOMER

2



1