

THIS COPY IS PROVIDED ON A RESTRICTED BASIS AND IS NOT TO BE USED IN ANY WAY DETRIMENTAL TO THE INTERESTS OF PANDUIT CORP.

TWIST TIE

NOTES:

1. SEE CATALOG FOR A COMPLETE LIST OF PARTS APPLICABLE FOR USE WITH THIS PART.
2. TERMINATED WITH (8 POSITION) MODULAR PLUGS AT BOTH ENDS PER T568B.
3. CONSTRUCTED WITH STRANDED CAT6 UTP 24AWG CM PATCH CABLE
4. MATERIALS:
PLUG: POLYCARBONATE
BOOT: CLEAR PVC
5. NOMINAL CABLE JACKET DIAMETER IS 0.235 IN (5.97MM)
6. PACKAGING: BULK PACKED 25 CORDS PER CARTON, WITHOUT BAGS.

STRAIN RELIEF BOOT

T568B WIRING SCHEME

PLUG POSITION:

- 1
- 2
- 3
- 4
- 5
- 6
- 7
- 8

CABLE WIRE:
WHITE/ORANGE
ORANGE
WHITE/GREEN
BLUE
WHITE/BLUE
GREEN
WHITE/BROWN
BROWN

| CABLE COLORS | ** = COLOR |
|--------------|------------|
| OFF WHITE | -- |
| BLACK | BL |
| BLUE | BU |
| RED | RD |
| YELLOW | YL |
| GREEN | GR |

IDENTIFICATION LABEL

TANGLE-FREE LATCH

MODULAR PLUG

PLUG POSITION 1

SEE SHEET 2 FOR
PATCH CORD LENGTHS
AND PART NUMBERS

| | | | |
|----------------------------------------------------------------------|--------------------|------------------------------|-------|
| PART NUMBER | | UTPSPXX**Y-Q | |
| TITLE | | | |
| TX6 PLUS UTP PATCH CORDS (CM) BULK PACKED | | | |
| CUSTOMER DRAWING | | | |
| ITEM REVISION NAME | | M02479QW/00 | |
| DATASET FILE NAME | | M02479QW_DC402/00B | |
| UNLESS OTHERWISE SPECIFIED, DIMENSIONAL TOLERANCES ARE: IN [mm] | | MATERIAL: | |
| .x ± | .xxx ± .010 [.3] | DRAWING NUMBER: 02479-402 | |
| .xx ± .03 [.8] | ANGLES ± | | |
| THIRD ANGLE PROJECTION | | SIZE | |
| DRAWN BY | DATE | CHK | SCALE |
| BJN | 11-21-11 | EJH | NONE |
| SHT 1 OF 2 | | A | |

| REV | DATE | BY | CHK | APR | DESCRIPTION | ECN |
|-----|----------|-----|-----|-----|------------------------|-----------|
| 1 | 4-3-14 | BJN | JSP | EJH | UPDATED | |
| R | 11-21-11 | BJN | EJH | EJH | RELEASED TO PRODUCTION | 02479-402 |

D10100DA/14

THIS COPY IS PROVIDED ON A RESTRICTED BASIS AND IS NOT TO BE USED IN ANY WAY DETRIMENTAL TO THE INTERESTS OF PANDUIT CORP.

TX6 PLUS UTP PATCH CORDS

| PANDUIT PART NUMBER | MIN. CABLE LENGTH | PANDUIT PART NUMBER | MIN. CABLE LENGTH |
|---------------------|-------------------|---------------------|-------------------|
| UTPSP3**Y-Q | 3 FT. | UTPSP2M**Y-Q | 2 METER |
| UTPSP4**Y-Q | 4 FT. | UTPSP3M**Y-Q | 3 METER |
| UTPSP5**Y-Q | 5 FT. | | |
| UTPSP6**Y-Q | 6 FT. | | |
| UTPSP7**Y-Q | 7 FT. | | |
| UTPSP8**Y-Q | 8 FT. | | |
| UTPSP9**Y-Q | 9 FT. | | |
| UTPSP10**Y-Q | 10 FT. | | |
| UTPSP11**Y-Q | 11 FT. | | |
| UTPSP12**Y-Q | 12 FT. | | |
| UTPSP13**Y-Q | 13 FT. | | |
| UTPSP14**Y-Q | 14 FT. | | |
| UTPSP15**Y-Q | 15 FT. | | |
| UTPSP16**Y-Q | 16 FT. | | |
| UTPSP17**Y-Q | 17 FT. | | |
| UTPSP18**Y-Q | 18 FT. | | |
| UTPSP19**Y-Q | 19 FT. | | |
| UTPSP20**Y-Q | 20 FT. | | |

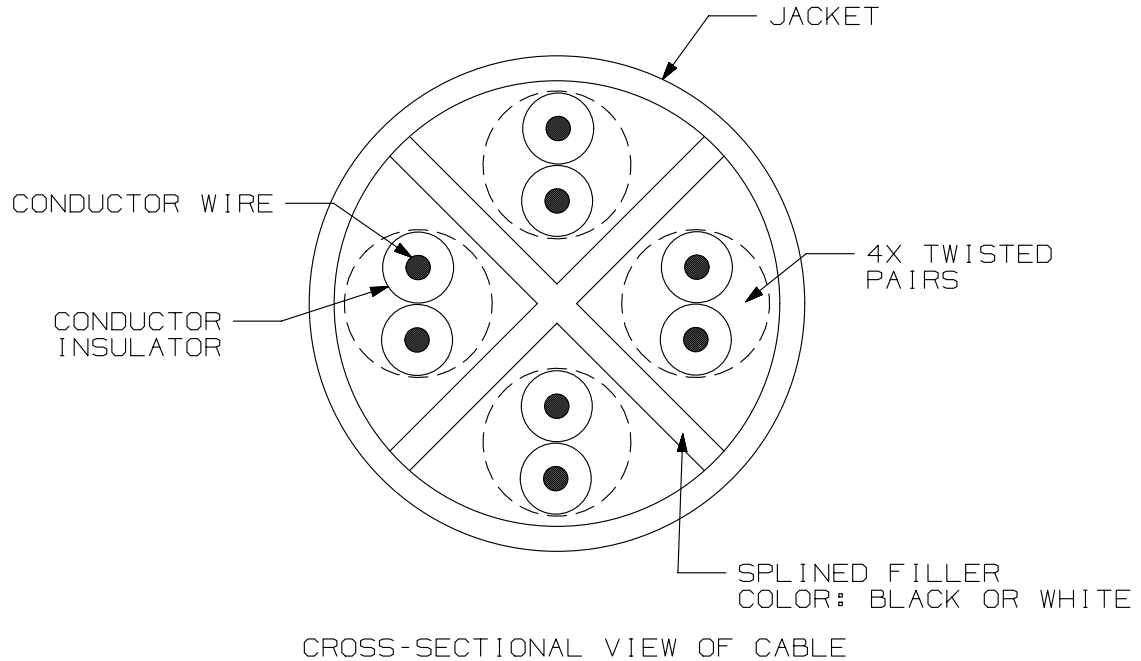

| | | | |
|-------------------------------------------------------------------|----------|------------------------|-------|
| PART NUMBER | | UTPSPXX**Y-Q | |
| TITLE | | | |
| TX6 PLUS UTP PATCH CORDS (CM) BULK PACKED | | | |
| CUSTOMER DRAWING | | | |
| ITEM REVISION NAME | | M02479QW/00 | |
| DATASET FILE NAME | | M02479QW_DC402/00B | |
| UNLESS OTHERWISE SPECIFIED, DIMENSIONAL TOLERANCES ARE: IN [mm] | | MATERIAL: | |
| .x ± .xx ± .03 [.8] | | DRAWING NUMBER: | |
| .xxx ± .010 [.3] | | 02479-402 | |
| ANGLES ± | | THIRD ANGLE PROJECTION | |
| DRAWN BY | DATE | CHK | SCALE |
| BJN | 11-21-11 | EJH | NONE |
| SHT 2 OF 2 | | | SIZE |
| | | | A |

| REV | DATE | BY | CHK | APR | DESCRIPTION | ECN |
|-----|----------|-----|-----|-----|---------------------------|-----------|
| 1 | 4-3-14 | BJN | JSP | EJH | SEE SHEET 1 FOR REVISIONS | 02479-402 |
| R | 11-21-11 | BJN | EJH | EJH | SEE SHEET 1 FOR REVISIONS | 02479-402 |

D10100DA/14