

THIS COPY IS PROVIDED ON A RESTRICTED BASIS AND IS NOT TO BE USED IN ANY WAY DETRIMENTAL TO THE INTERESTS OF PANDUIT CORP.

- NOTES:
1. VISIT OUR ON-LINE CATALOG AT WWW.PANDUIT.COM FOR A LIST OF CURRENT PARTS APPLICABLE FOR USE WITH THIS PRODUCT.
  2. DIMENSIONS IN [ ] ARE METRIC.
  3. ALL MATERIALS AND COMPONENTS USED MEET THE MATERIAL RESTRICTIONS OF RoHS (EUROPEAN DIRECTIVE 2011/65/EU ON THE RESTRICTION OF HAZARDOUS SUBSTANCES) AS PROPOSED BY THE RoHS TECHNICAL ADAPTATION COMMITTEE.
  4. WEIGHT: 5.63 lbs/2.55 kg
  5. PART INCLUDES:  
POWER SUPPLY UNIT ASSEMBLY (1)
  6. THIS PRODUCT COMPLIES TO:  
UL 1400-1 FAULT-MANAGED POWER SYSTEMS

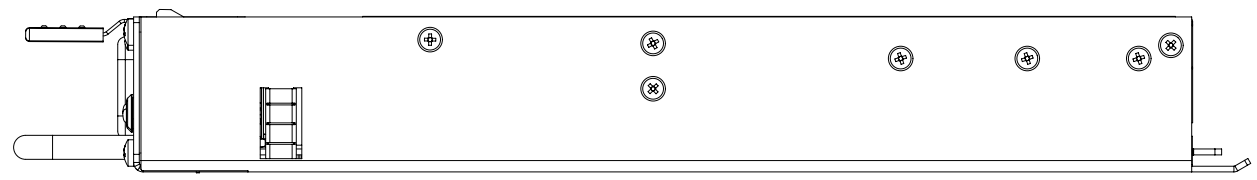
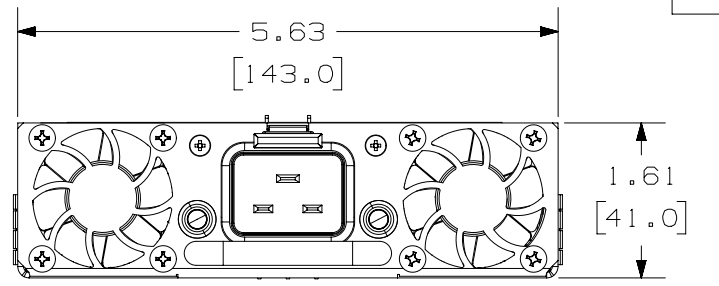
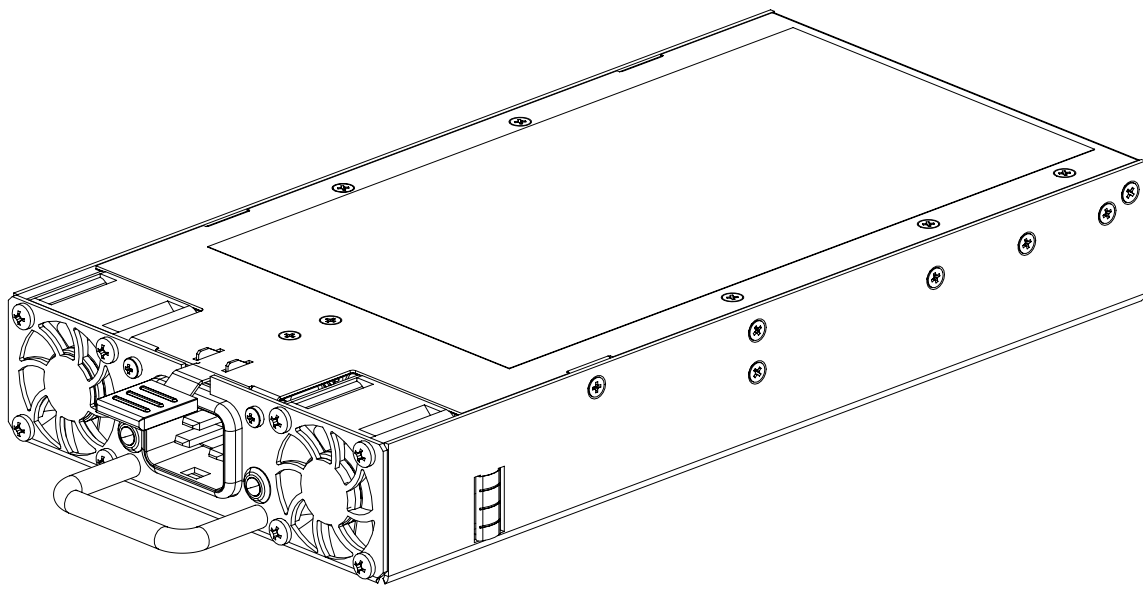
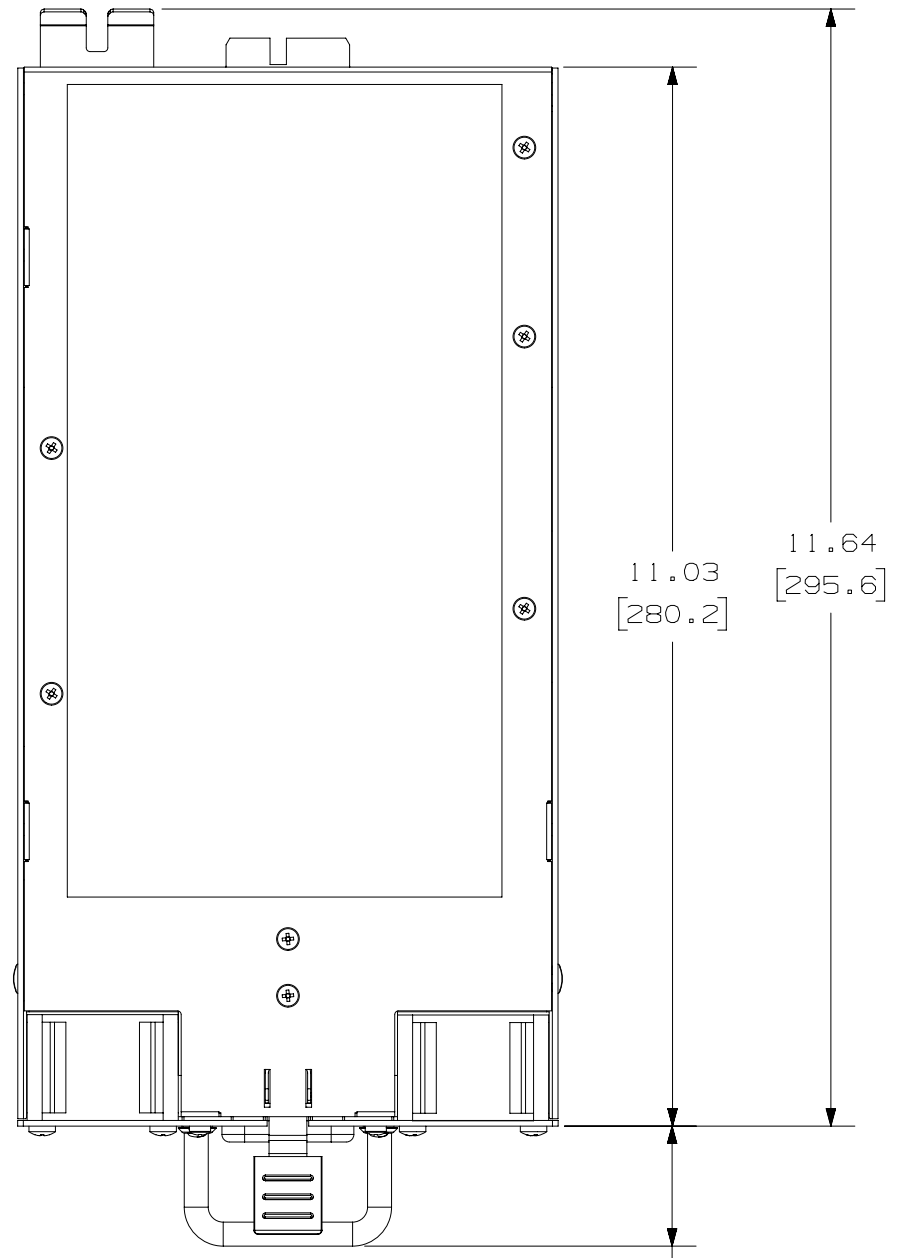
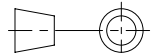

PART NUMBER		PXU1AJANNXX	
TITLE		FMPS Power Supply Unit 1600W	
		CUSTOMER DRAWING	
ITEM REVISION NAME	01959NCZ/01		
DATASET FILE NAME	01959NCZ_DC/01		
		THIRD ANGLE PROJECTION	
MATERIAL	XXXXXXXXXXXX		DRAWING NUMBER
			01959NCZ - DC
DRAWN BY	DATE	CHK	SCALE
DFTR	XX/XX/XX	ENG	NONE
SHEET 1 OF 1			SIZE
			B

REV	DATE	BY	CHK	APR	DESCRIPTION	ECN
00	10/25/23	FRCH	FRCH	PM	INITIAL RELEASE	

B-SIZE CUSTOMER