

THIS COPY IS PROVIDED ON A RESTRICTED BASIS AND IS NOT TO BE USED IN ANY WAY DETRIMENTAL TO THE INTERESTS OF PANDUIT CORP.

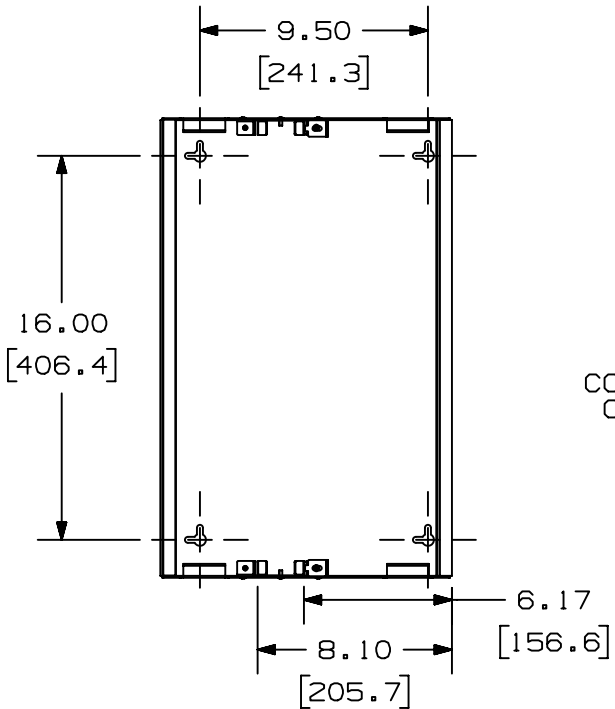

COVER
OFF

- NOTES:
1. VISIT OUR ON-LINE CATALOG AT WWW.PANDUIT.COM FOR A LIST OF CURRENT PARTS APPLICABLE FOR USE WITH THIS PRODUCT.
 2. DIMENSIONS IN [] ARE METRIC.
 3. ALL MATERIALS AND COMPONENTS USED MEET THE MATERIAL RESTRICTIONS OF RoHS (EUROPEAN DIRECTIVE 2011/65/EU ON THE RESTRICTION OF HAZARDOUS SUBSTANCES) AS PROPOSED BY THE RoHS TECHNICAL ADAPTATION COMMITTEE.
 4. WEIGHT: 12 lbs [5443 g]
 5. PART INCLUDES:
 - (1) - BASE
 - (1) - COVER
 6. COMPATIBLE WITH PANDUIT 1RU PATCH PANELS (SOLD SEPARATELY)
 7. UL COMPLIANT FOR USE IN AIR HANDLING SPACES

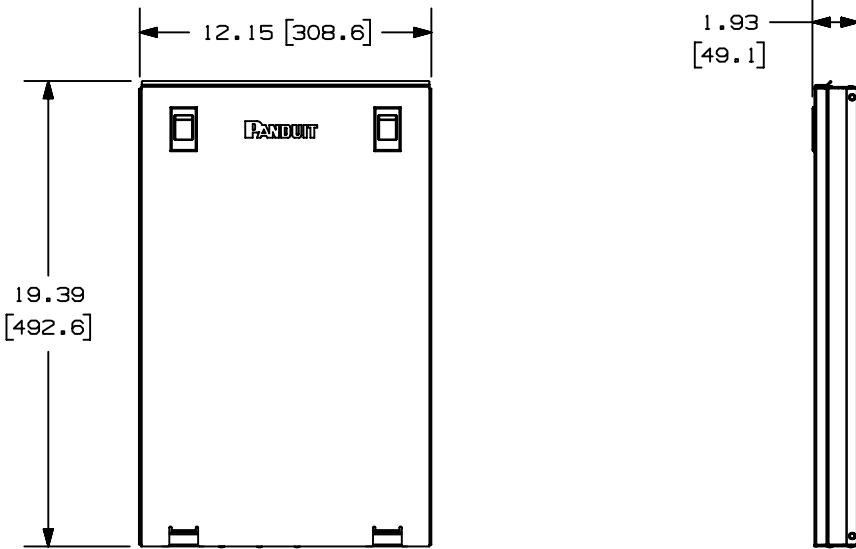
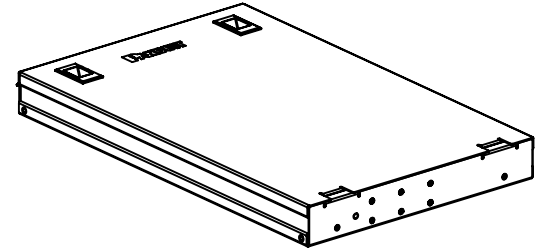

PART NUMBER		CPB24BL		
TITLE		24 PORT CONSOLIDATION POINT BOX		
ITEM REVISION NAME		CUSTOMER DRAWING		
DATASET FILE NAME		01335NAM/04		
MATERIAL		STEEL		
DRAWING NUMBER		01335NAM-DC		
DRAWN BY		DATE	CHK	SCALE
BJN		11-4-19	BSN	NONE
SHEET 1 OF 1		A		

REV	DATE	BY	CHK	APR	DESCRIPTION	ECN
04A	3-11-24	TWV	BSN	TAM	REMOVED MOUNTING BRACKETS ADDED UL NOTE	M09000VK
01A	11-4-19	BJN	BSN	BETL	RELEASED TO PRODUCTION	M09000KT