

# Opticom® Cassette Splitters

## SPECIFICATIONS

The Splitter Cassette shall provide 1x4, 2x4, 1x8, and 2x8 split ratios for use in Multi-Purpose Enclosures, zero-RU brackets, and other Opticom form-factor management products. The cassettes shall utilize SC/APC connectivity in duplexed output ports and simplex input ports, which follow ANSI/TIA standard colors for identification. The device shall provide an even split ratio across the operating wavelengths.



## TECHNICAL INFORMATION

<b>Split ratios:</b>	1X4, 2X4, 1X8, 2X8
<b>Fiber type:</b>	9/125µm Singlemode
<b>Operating wavelength:</b>	1260-1650 nm
<b>Directivity:</b>	> 55dB
<b>Return loss:</b>	> 55dB
<b>Maximum operating power:</b>	300 MW
<b>Connectivity:</b>	SC/APC
<b>Storage and operating temperature ranges:</b>	-40°C to 85°C

## Opticom Cassette Splitters

<b>Opticom SC-APC splitter cassette, 1X4 split:</b>	FC29N-04-3G1X04
<b>Opticom SC-APC splitter cassette, 2X4 split:</b>	FC29N-04-3G2X04
<b>Opticom SC-APC splitter cassette, 1X8 split:</b>	FC29N-08-3G1X08
<b>Opticom SC-APC splitter cassette, 2X8 split:</b>	FC29N-08-3G2X08

## APPLICATIONS

Deployment of discrete optical splitters for use in passive optical LAN and Broadband installations including end-of-row, wall-mount, or in-ceiling zone enclosures and telco closets.

## ENGINEERING DRAWINGS

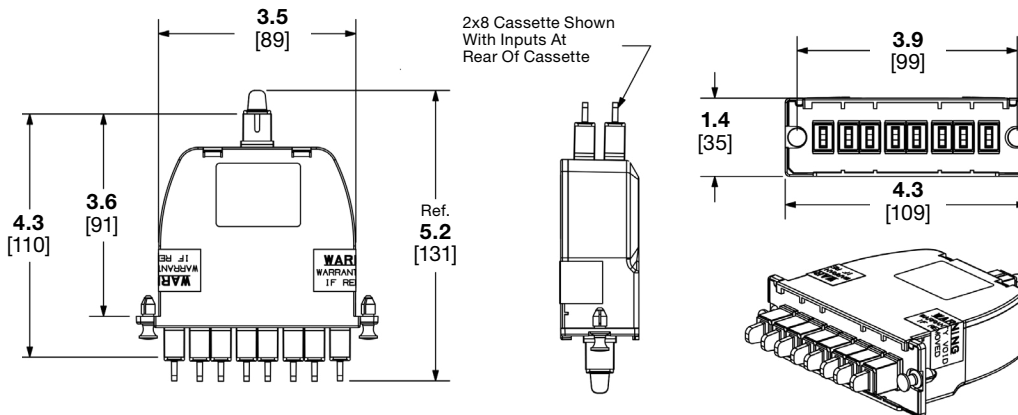

## WORLDWIDE SUBSIDIARIES AND SALES OFFICES

PANDUIT US/CANADA  
Phone: 800.777.3300

PANDUIT EUROPE LTD.  
London, UK  
Phone: 44.20.8601.7200

PANDUIT SINGAPORE PTE. LTD.  
Republic of Singapore  
Phone: 65.6305.7575

PANDUIT JAPAN  
Tokyo, Japan  
Phone: 81.3.6863.6000

PANDUIT LATIN AMERICA  
Guadalajara, Mexico  
Phone: 52.33.3777.6000

PANDUIT AUSTRALIA PTY. LTD.  
Victoria, Australia  
Phone: 61.3.9794.9020

For a copy of Panduit product warranties, log on to [www.panduit.com/warranty](http://www.panduit.com/warranty)



For more information  
**Visit us at [www.panduit.com](http://www.panduit.com)**  
Contact Customer Service by email: [cs@panduit.com](mailto:cs@panduit.com)  
or by phone: 800.777.3300

© 2024 Panduit Corp.  
ALL RIGHTS RESERVED.  
FBSP267-WW-ENG  
4/2024