



Fiber Optic Infrastructure Application Guide

Deploying a Fiber Optic Physical
Infrastructure to Support Converged
Plantwide EtherNet/IP

November 2011

About *PANDUIT*

PANDUIT is a world-class developer and provider of leading-edge solutions that help customers optimize the physical infrastructure through simplification, agility and operational efficiency. PANDUIT's Unified Physical Infrastructure (UPI) based solutions give enterprises the capabilities to connect, manage and automate communications, computing, power, control and security systems for a smarter, unified business foundation. Strong relationships with technology leaders complemented with its global staff and unmatched service and support, make PANDUIT a valuable and trusted partner.

About *ROCKWELL AUTOMATION*

ROCKWELL AUTOMATION is a leading global provider of industrial automation power, control, and information solutions that help manufacturers achieve a competitive advantage in their businesses. The company brings together leading global brands in industrial automation which includes Allen-Bradley controls and services and Rockwell Software factory management software. Headquartered in Milwaukee, Wisconsin, the company employs about 20,000 people serving customers in more than 80 countries.

About *CISCO*

Cisco is the worldwide leader in networking that transforms how people connect, communicate and collaborate. Information about Cisco can be found at <http://www.cisco.com>.

Copyright Information

Copyright 2011, Panduit Corp., Cisco Systems, Inc., and Rockwell Automation, Inc.

Trademark Information

Cisco is a registered trademark of Cisco Systems, Inc. and/or its affiliates in the U.S. and certain other countries.

ODVA and EtherNet/IP are trademarks owned and used by ODVA.

Rockwell Automation and FactoryTalk are registered trademarks of Rockwell Automation in the United States and/or other jurisdictions.

Stratix 8000, Stratix 6000, and Stratix 2000 are trademarks owned and used by Rockwell Automation and its various subsidiary entities.

Disclaimer

THE INFORMATION CONTAINED HEREIN IS INTENDED AS A GUIDE FOR USE BY PERSONS HAVING TECHNICAL SKILL AT THEIR OWN DISCRETION AND RISK, AND IS PROVIDED "AS IS." PANDUIT, ROCKWELL AUTOMATION, AND CISCO DISCLAIM ALL WARRANTIES, INCLUDING, WITHOUT LIMITATION, THE WARRANTIES OF MERCHANTABILITY, FITNESS FOR A PARTICULAR PURPOSE, AND NONINFRINGEMENT, AND FURTHER NO WARRANTIES ARE CREATED WITH RESPECT TO ANY COURSE OF DEALING, USAGE, OR TRADE PRACTICE, IN CONNECTION WITH INFORMATION CONTAINED HEREIN OR ITS IMPLEMENTATION. PANDUIT AND ROCKWELL AUTOMATION DISCLAIM ANY LIABILITY ARISING FROM ANY USE OF THIS DOCUMENT OR THE INFORMATION CONTAINED HEREIN, OR FOR THE ABSENCE OF SAME. INFORMATION CONTAINED IN THIS DOCUMENT DOES NOT CONSTITUTE THE TECHNICAL OR OTHER ADVICE OF PANDUIT OR ROCKWELL AUTOMATION.

About the Authors

| | |
|---|--|
| <p>Dan McGrath, Solutions Manager, Panduit</p> <p>Dan manages the Industrial Automation research efforts for <i>PANDUIT</i>'s control panel and industrial networking solutions, including collaborative research conducted with Rockwell Automation in EMI noise mitigation for control systems. He has over 20 years experience designing and supporting control systems, factory data collection and industrial networks for global manufacturing operations. He holds a BS degree in Electrical Engineering and has attained Professional Engineer and ASQ Certified Quality Engineer certifications.</p> | <p>Scott Johnston, Consultant, Network & Security Services, Rockwell Automation</p> <p>Scott is a Network & Security Services Consultant for Rockwell Automation. Scott is responsible for Network Infrastructure Design services with a focus on Ethernet. Scott has worked in the industry for 22 years, with 14 years at Rockwell Automation, providing customer centric solutions in a variety of roles including sales support, solution provider, and educator with the last five years dedicated to industrial networking.</p> |
| <p>Gregory Wilcox, Business Development Manager for Networks, Rockwell Automation</p> <p>Gregory leads a multi-company effort to establish tested and validated design guidelines that help manufacturers design and deploy large-scale automation network infrastructures. As a major contributor to the Cisco and Rockwell Automation Alliance, Gregory has advanced the adoption of convergence between industrial and IT networks. Gregory has been designing and implementing industrial network solutions for the past 27 years, with 22 of those years at Rockwell Automation, holding roles of increasing responsibility such as Application Engineer and Solution Architect, resulting in extensive experience in developing control and information solutions for industrial applications. Prior to joining Rockwell Automation, Gregory worked in the Defense industry developing industrial automation and control system solutions for discrete and process applications.</p> | <p>Paul Didier, Industry Solutions Architect for Manufacturing, Cisco</p> <p>Paul is an Industry Solutions Architect for Manufacturing. He is responsible for developing solutions for the Manufacturing vertical, including those for Industrial Automation and Control Systems. Paul is a member of the ODVA Technical Review Board and has over 22 years of industry experience. Prior to joining Cisco, Paul was an Associate Partner with a focus on IT Infrastructure at Accenture for 16 years and an IT Manager for SAP for 2 years. He has extensive experience working for Manufacturing, Retail, and Financial Services clients. He has developed and deployed large enterprise IT applications for a range of business functions on a global scale.</p> |
| <p>Robert Reid, Sr. Product Development Manager, Network Connectivity Group, Panduit</p> <p>Robert Reid currently defines product development direction for Panduit's fiber optic structured cabling product line. He has been active in the fiber optics industry for over twenty-five years including the development of passive optical components, optoelectronic and specialty optics and systems. Mr. Reid has presented at many industry symposia (Optical Fiber Conference, OE/Fibers, IMAPS & ISHM). He has also contributed significantly to the development of EIA/TIA Fiber Optic Test Procedures as well as having served as membership chair to EIA/TIA FOLS (Fiber Optic LAN Section). Mr. Reid has an undergraduate degree in Physics from the University of Waterloo (Canada) and a graduate degree in Statistics from the University of Hartford.</p> | <p>Doug Swalec, Senior Fiber Applications Engineer, Panduit</p> <p>Doug assists with design, implementation and troubleshooting all fiber solutions provided by <i>PANDUIT</i>. He assists with writing technical collateral to assist with the understanding and proper usage of Panduit fiber solutions. He holds a Bachelor of Science in Electrical Engineering and his extensive fiber background includes design, install, testing, and maintaining fiber optic networks; encompassing everything from LAN technologies to high speed fiber backbones.</p> |

Preface

Successful deployment of EtherNet/IP within a Rockwell Automation Integrated Architecture depends on a robust network infrastructure, starting with a stout physical layer that currently includes, and in some cases requires, fiber optic connectivity. This application guide details the fiber optic network infrastructure solutions from Rockwell Automation, Cisco, and Panduit that provide new, high-performance connectivity options to increase the integrity and availability of EtherNet/IP networks at each level of your plant network.

This guide describes the following:

- How to leverage fiber across the physical infrastructure to enable industrial network convergence for improved performance and robustness
- New topologies for device-level applications requiring the deployment of fiber ring and linear topologies within and between control panels, which require robust connectivity, effective wire management practices for slack and bend radius control, environmental hardening, and security risk management for successful network operation
- How to specify fiber optic distribution cabling that is rated for plant environments or protected from environmental risks, with solutions that allow the use of legacy cable where appropriate
- The use of distributed cabling topologies and patching technologies, which enhances the flexibility and scalability of EtherNet/IP networks to achieve greater operational efficiencies
- Physical media considerations for fiber optic systems, including panel solutions, field solutions, physical routing solutions, grounding/bonding/shielding, and control room solutions
- Logical and physical framework design recommendations developed by Panduit, Rockwell Automation, and Cisco to help customers improve the data availability and integrity of their EtherNet/IP network physical infrastructure
- Panduit networking infrastructure solutions that enable best practices for fiber implementation across industrial automation, connected building, and data center applications
- Rockwell Automation fiber networking components for industrial Ethernet switches, programmable automation controller (PAC) communication cards, and device-level rings that enable fiber to be implemented across your automation system
- Cisco solutions for fiber optic networking at higher levels of the plant network for improved performance and robustness

1. Introduction

Industry adoption of EtherNet/IP for control and information has driven the wide deployment of standard Ethernet within manufacturing. This adoption has triggered migration from the traditional three-tier industrial network model to a converged plantwide EtherNet/IP industrial network model, as shown in [Figure 1](#).

Plantwide deployment of EtherNet/IP requires an industrial network design methodology. Following a methodology helps create a structure and hierarchy to help maintain real-time network performance. In addition, it helps enable the convergence of multiple control and information disciplines, including data collection, configuration, diagnostics, discrete, process, batch, safety, time synchronization, drive, motion, energy management, voice, and video.

Figure 1 Converged Plantwide EtherNet/IP Industrial Network Model

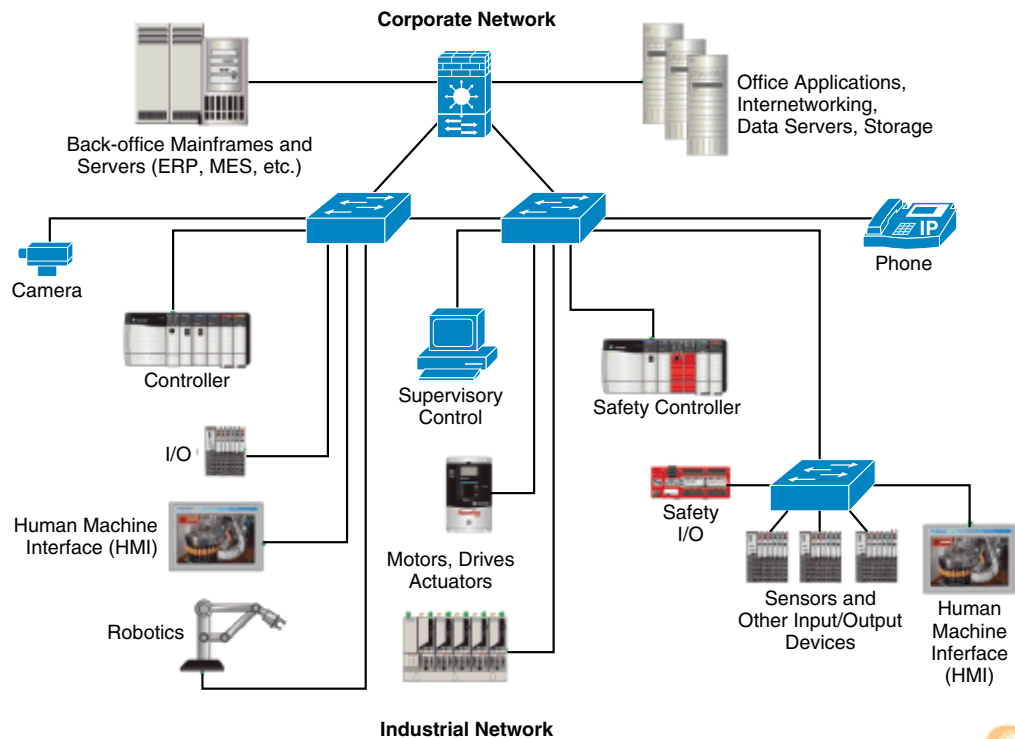

291873

Key elements of a successful EtherNet/IP network design include the following:

- Understanding application and functional requirements
 - Listing devices to be connected: industrial and non-industrial
 - Determining data requirements for availability, integrity, and confidentiality
 - Documenting communication patterns, topology, and resiliency requirements
 - Types of traffic: information, control, safety, time synchronization, motion control, voice, video
- Developing a logical framework (roadmap)
 - Defining zones and segmentation (for example, VLANs)
 - Placing applications and devices in the logical framework based on requirements
- Developing a physical framework to align with and support the logical framework
- Determining security requirements, taking into consideration IT requirements, and establishing early dialogue with IT
- Using technology and industry standards, reference models, and reference architectures

For additional information, see the Rockwell Automation Top 10 Recommendations for Plantwide EtherNet/IP Deployments whitepaper, publication ENET-WP022, which can be accessed at the following URL:

http://literature.rockwellautomation.com/idc/groups/literature/documents/wp/enet-wp022_en-e.pdf.

Today, EtherNet/IP is providing great value in the manufacturing production plant floor environment. Copper connectivity, which most users associate with simple plug-and-play networking, has the following challenges:

- Unsuitability for the long runs (over 100m)
- Vulnerability to extreme electromagnetic interference (EMI) environments
- Slower network recovery when used for resilient inter-switch connectivity because of slow link-loss detection

Fiber media provides advantages over copper in these situations. However, users are often cautious when considering whether to deploy fiber, with concerns that fiber cabling is too complicated and expensive to specify, design, and install. The benefits of fiber for manufacturing include the following:

- Preferable for inter-switch connectivity
- Faster convergence for network resiliency recovering from faults and topology changes
- Useful for applications outdoors or between buildings
- Useful when the link distance is beyond the reach of copper (100m)
- Delivers EMI immunity

A unified approach to physical and logical systems architecture is imperative for solutions to fully address the need for availability, agility, integration, and security. Panduit has developed the industry's most comprehensive and holistic approach to a Unified Physical Infrastructure (UPI) to help enterprises and plants align, converge, and optimize critical systems—communication, computing, control, power, and security—to build a smarter, unified business foundation.

This application guide is provided by Panduit, Cisco, and Rockwell Automation to help customers understand and deploy fiber network infrastructure in plant environments. As such, this can be viewed as an extension to the Cisco and Rockwell Automation Converged Plantwide Ethernet (CPwE) solution, which is available at the following URL:

http://literature.rockwellautomation.com/idc/groups/literature/documents/td/enet-td001_-en-p.pdf.

This guide is also an extension of the Panduit UPI approach, and is designed to identify reference solutions that reflect new fiber optic physical layer realities in the industrial space.

2. Fiber Application Reference Architectures

This section discusses guidelines and recommendations to design, specify, install, commission, and troubleshoot fiber optic cable for EtherNet/IP solutions within the Cisco and Rockwell Automation CPwE architectures. [Figure 2](#) shows an overview of the complete CPwE logical model, incorporating all elements of a standard plant network. The CPwE logical model segments devices and equipment into hierarchical functions. This model identifies levels of operations and defines logical plant network segmentation for each level. For the purpose of this guide, the CPwE term manufacturing zone is used generically to represent industrial systems such as industrial automation and control, process automation, process control, and supervisory control and data acquisition. For additional information, see the following guides:

- Cisco and Rockwell Automation Converged Plantwide Ethernet (CPwE) Design and Implementation Guide:
http://www.cisco.com/en/US/docs/solutions/Verticals/CPwE/CPwE_DIG.html
- Rockwell Automation publication ENET-TD001:
http://literature.rockwellautomation.com/idc/groups/literature/documents/td/enet-td001_-en-p.pdf

Figure 2 CPwE Logical Model

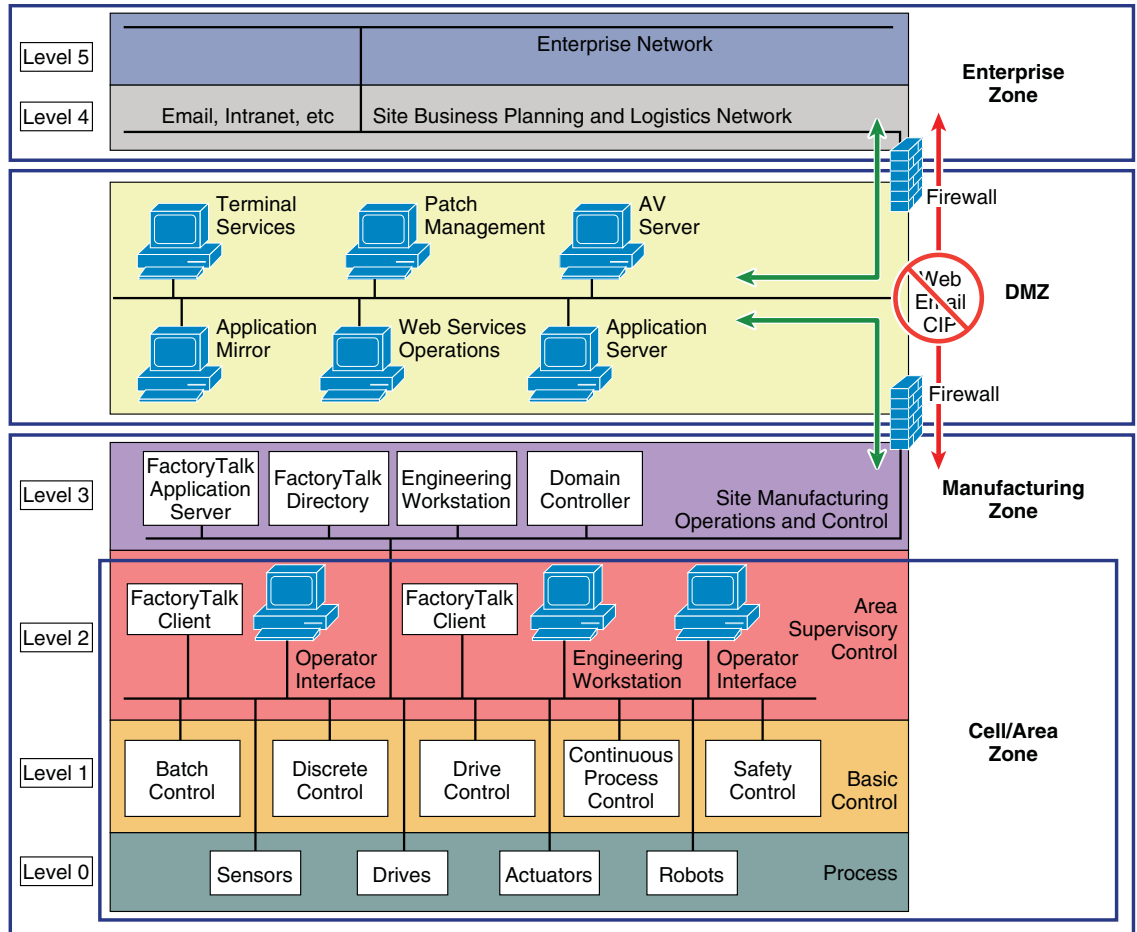





Table 1 summarizes the organization of this section, starting with the CPwE cell/area zone and moving through key areas of the plant network to finish at the CPwE manufacturing zone. For each network area, a reference architecture is provided that includes a schematic reference layout, a bill of materials (BOM), and a sample image.

Table 1 Physical Infrastructure Reference Architecture Levels and Fiber Strategy

| Physical Level | | Fiber Strategy |
|---|--|--|
| Cell/area zone Levels 0-1 End device and controller |  | Use fiber for noise-immune, high-performance connectivity for linking devices in ring or linear topologies |

Table 1 Physical Infrastructure Reference Architecture Levels and Fiber Strategy (continued)

| Physical Level | | Fiber Strategy |
|---|---|--|
| <p>Cell/area zone Levels 0–2 Control panel</p> |  | <p>Secure, testable, high-performance fiber uplinks for panel-mounted switches</p> |
| <p>Manufacturing zone Levels 0–2 Network zone cabling</p> |  | <p>Robust, cost-effective, safe zone architecture for distributing fiber connectivity across the plant floor</p> |
| <p>Manufacturing zone Level 3 Micro data center (Core to distribution, distribution to access)</p> |  | <p>Secure, high-performance connection of plant floor fiber networks to higher level switches and servers</p> |

Zone Cabling Architecture Characteristics

A highly effective way to deploy EtherNet/IP solutions throughout the CPwE architecture is to physically distribute cabling runs using a zone cabling architecture for all plant networks. Zone cabling enables facility systems to be converged with Ethernet cabling pathways as they are being designed. This converged multi-technology backbone comprises Category 5e/6/6A copper, optical fiber, coaxial, RS-485, and other fieldbus cabling. These systems are converged within a common pathway and then terminated within zone enclosures distributed throughout the plant (see Figure 3).

A zone cabling architecture with Stratix switches in network zone enclosures provides a platform for implementing small VLANs for cell/area zones as recommended under CPwE to improve manageability and limit Layer 2 broadcast domains. The VLAN approach allows one zone enclosure to feed network connections to high priority manufacturing control system nodes as well as lower priority connections for printers or data collection, while segmenting and isolating traffic. The network segmentation for these VLANs is made visible using features of the Panduit physical infrastructure, including color coding for the patch fields and physical security such as lock-in/blockout devices on connection points or physical keying solutions that prevent inadvertent patching mistakes.

Figure 3 Comparison Floor Plan Layouts Between Traditional and Zone Cabling Architectures

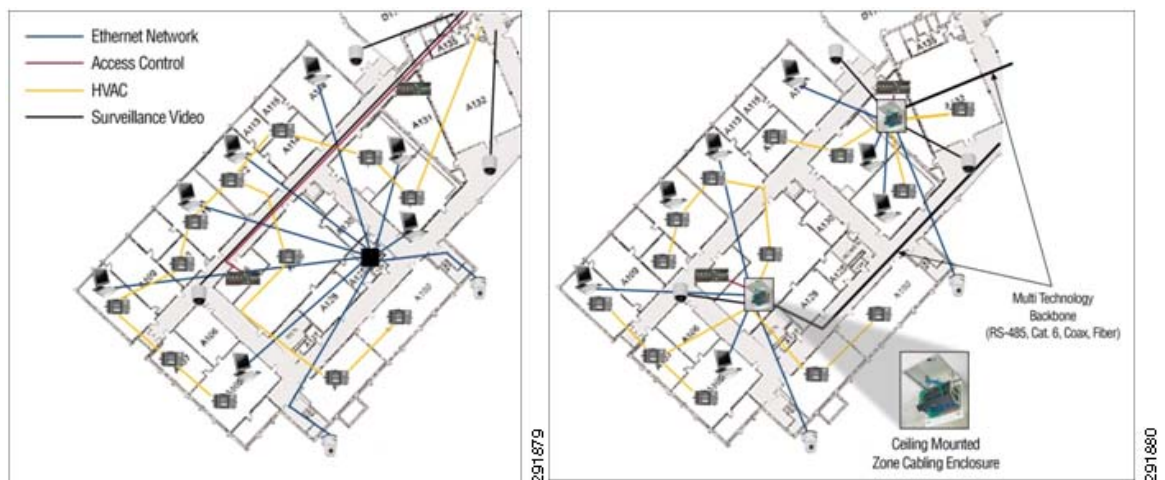

Traditional (Home Run) Cabling Infrastructure

Converged (Zone) Cabling Infrastructure

It is critical that uplinks from the network zone enclosure maintain very high availability and performance, benefits that can be achieved by deploying robust fiber optic cabling channels. As described in the Converged Plantwide Ethernet (CPwE) Design and Implementation Guide (ENET-TD001)—http://literature.rockwellautomation.com/idc/groups/literature/documents/td/enet-td001_-en-p.pdf, fiber offers faster recovery and convergence times for these uplinks as compared to copper.

Specifically, the convergence time to recover and restore from a failed path condition depends on several factors. In restoration, switching occurs after backup paths are computed following the receipt of failure notification. The convergence time to recover a single path is given by the sum of the following factors:

- Signal delay: time to signal a network failure between nodes
- New path processing delay: time taken to compute an alternate path
- New path reservation delay: time required to reserve on newly computed path

- Switching delay: the time required to switch from affected path to new path

Switching and signaling delays are affected by media length and PMD chosen (Fiber/UTP), whereas processing and reservation time are independent of such. For a detailed experimental validation of convergence time over different media/PMDs, refer to joint RA/Cisco work on network resiliency: http://www.cisco.com/en/US/docs/solutions/Verticals/CPwE/CPwE_chapter3.html

A redundant star or fiber ring using robust fiber media such as armored fiber provides a high performance and resilient network backbone for a zone architecture to handle current traffic with bandwidth for future needs. Installing an Uninterruptible Power Supply (UPS) in the network zone enclosure provides conditioned power and backup for power outages to keep network availability maximized.

The zone enclosures become network consolidation points, allowing all cables to be managed and patched in a single enclosure. This architecture differs from typical cabling architectures in which multiple lengthy dedicated (and redundant) cabling is routed along disparate pathways, which leads to inefficiencies in specification, installation, and maintenance. In contrast, better segmentation of RS 485/232 networks for both troubleshooting and singular cable pulls saves installation time and cost.

With a zone cabling architecture approach, network cabling becomes easier to locate, manage, and maintain because each additional building system is routed within the same pathways and enclosures. In this way, managed cabling reduces the number of home runs throughout a facility and also helps eliminate abandoned cable in plenum spaces, helping make the workplace run more efficiently and safely.

Micro Data Center Characteristics

A micro data center (MDC) is a versatile combination of hardware, software, and cabling that serves as an end-to-end networking hub, similar to a telecommunications or network room but on a much smaller scale than the typical enterprise data center. The defining characteristic of an MDC is that it houses a complete data center infrastructure in a single space (electronic devices, patch fields, cable management, grounding/bonding, power, and copper/fiber cabling), yet is sized to serve the demands of a manufacturing environment.

The MDC houses the CPwE Level 3 site operation's switches and servers. The MDC can also house the services, servers, firewalls, and switches of the CPwE demilitarized zone (DMZ). MDCs typically house storage arrays for plant historians for production and process data that may be replicated or consolidated for use for enterprise-level applications outside the DMZ. Virtualization and storage arrays can form the basis for high availability architectures for critical manufacturing applications. A key to a successful MDC implementation is to implement a physical infrastructure that promotes network segmentation and zoning by leveraging best practices for patching, cable management, organization, and physical security. The design features of Panduit's MDC solution include patching for testability for the critical fiber and copper connections to create a structured cabling system that can be fully validated using common tools and test procedures that are well established in standards and IT practice. The Panduit solution also enables a measure of resiliency and improved uptime (see the previous section for information on recovery and convergence times for fiber and copper uplinks).

The cable management features include panels optimized for slack management and bend radius control to protect fiber performance. The levels for enterprise, DMZ, and manufacturing in the rack units of the MDC rack or cabinet network segmentation can be made visibly evident by mapping zones using color coding and other identification features. A solid defense in depth for security requires a solid physical security foundation so that locked cabinets and the use of physical security on the fiber and copper connections improve overall mistake proofing and protection.

The MDC is a relatively new concept, representing the next phase in the transition from tower computing systems in a manufacturing environment to rack- and cabinet-based deployments, and can serve a variety of purposes in the enterprise. From a logical architecture perspective, the MDC is positioned between the plant floor and the enterprise data center (see Figure 4). It typically features a segmented network architecture separating the plant network from the rest of the enterprise. This network segmentation helps to thwart viruses and other unwanted user intrusions, while ensuring maximum bandwidth dedicated for manufacturing.

Figure 4 Micro Data Center Application in the CPwE Architecture

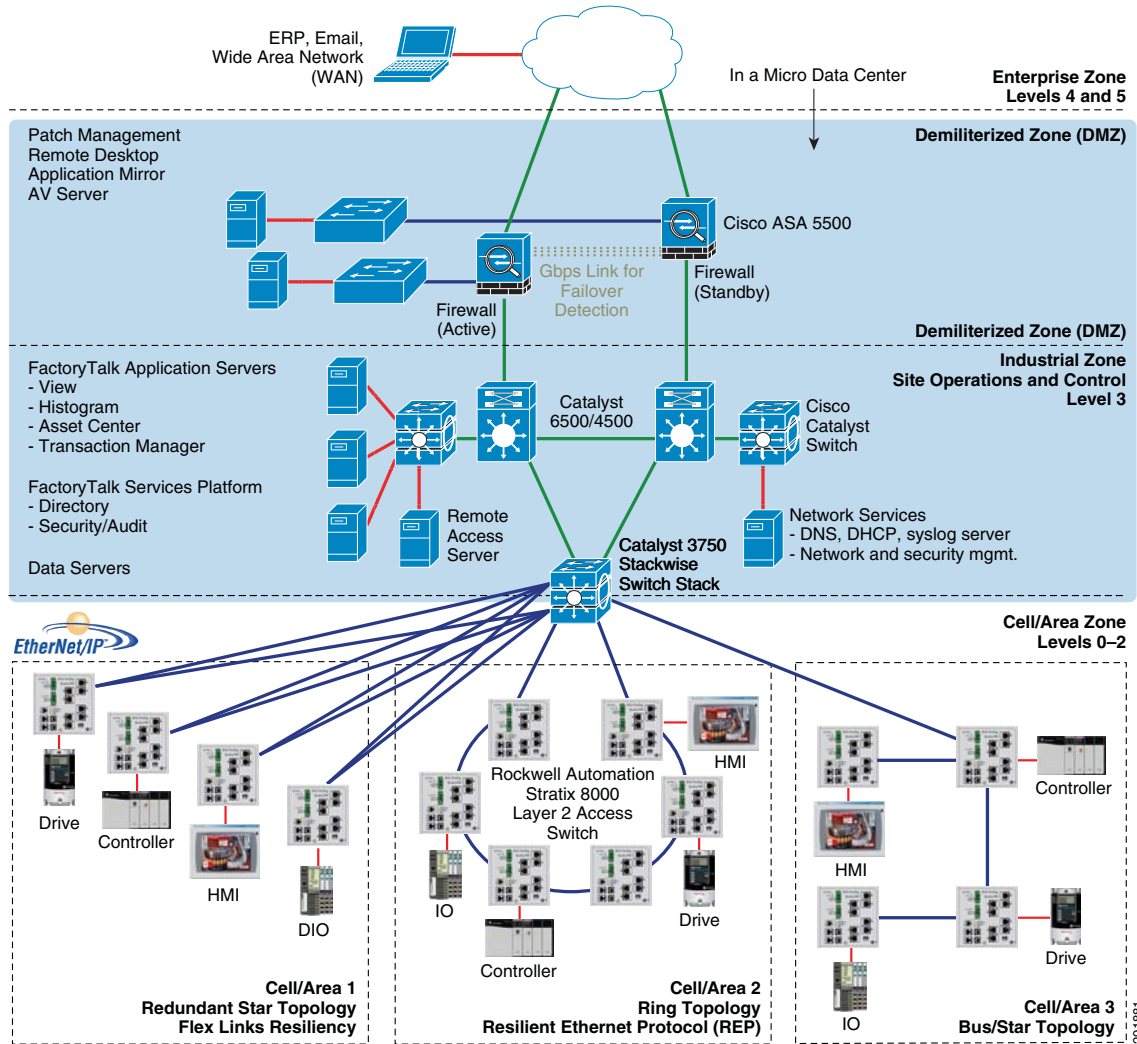

Cell/Area Zone – Levels 0-1 – End Device and Controller

Embedded switch technology embeds popular Layer 2 switch features directly into EtherNet/IP devices and controller hardware to support high performance applications, without the need for additional configuration. This technology enables device-level linear and ring topologies for EtherNet/IP applications. These types of devices are found in levels 0-1 of the CPwE logical model.

An example of the EtherNet/IP embedded switch technology is the Allen-Bradley 1783-ETAP2F EtherNet/IP fiber tap shown in Figure 5, which has one copper and two fiber ports. The two fiber ports allow for the fiber topology to be connected between the ETAP devices to form a ring or linear topology.

Figure 5 Sample Device-Level Fiber Optic Deployment



The connectivity for the ETAP is an LC small form factor-based connector combined with either 62.5 μ m or 50 μ m fiber media. The 100BASE-FX technology provided by the ETAP can be sufficiently run on either 62.5 μ m or 50 μ m multimode fiber (MMF) cabling, with a maximum reach from ETAPs of 2km as specified in the 100BASE-FX standard.

Along with the reach constraints (see Table 11), the fiber link budget plays an important function in determining which type of fiber media (62.5 μ m or 50 μ m) will be used to run the network. The fiber link budget consists of connectivity loss and media loss across the entire link. For the 1783-ETAP2F model shown connected together, a 62.5 μ m cabling system is allocated a loss budget of 8dB, while a 50 μ m cabling system is allocated a loss budget of 4dB (fiber link budgets are discussed in 3. Fiber Optic Cabling Systems – Options and Considerations for Selection/Installation).

Testing the link between the ETAP and the Layer 2/3 switch (Stratix) can be accomplished by using TIA/EIA-526-14. To ensure that fiber links are tested and cleaned properly according to the standards, Panduit provides the following best practices documents:

- Permanent Link Testing of Multimode and Singlemode Fiber Optic Cabling Systems (PN445)—<http://www.panduit.com/groups/MPM-OP/documents/BestPractice/110255.pdf>
- Visual Inspection and Cleaning of Multimode and Singlemode Structured Cabling System Interconnect Components (PN446)—<http://www.panduit.com/groups/MPM-OP/documents/BestPractice/109063.pdf>

Installation of the fiber cabling from the ETAP to the control panel that houses the Layer 2 switch(es) depends on the Mechanical, Ingress, Chemical/Climatic, and Electromagnetic (M.I.C.E.) level of the environment through which the cable is pulled, as well as the type of fiber cabling being installed (see Figure 17 for more information on M.I.C.E. levels). The type of fiber optic cabling is usually either indoor armored cabling or distribution type cabling (see Table 10 for fiber cabling types). Cabling can either be pre-terminated (connectors are pre-installed) or raw (connectors are installed after the cabling is pulled into place). When installing the fiber cabling system, always follow the Panduit best

practices document Cable Preparation and Pulling Procedure: Best Practices for Fiber Optic Indoor Tight-Buffered Cable (PN447B) at the following URL:
<http://www.panduit.com/groups/MPM-OP/documents/BestPractice/109056.pdf>

The layout in Figure 6 and the BOM in Table 2 represent the fiber connectivity necessary to complete the link between the ETAPs.

Figure 6 Device-Level (All Fiber) Reference Layout

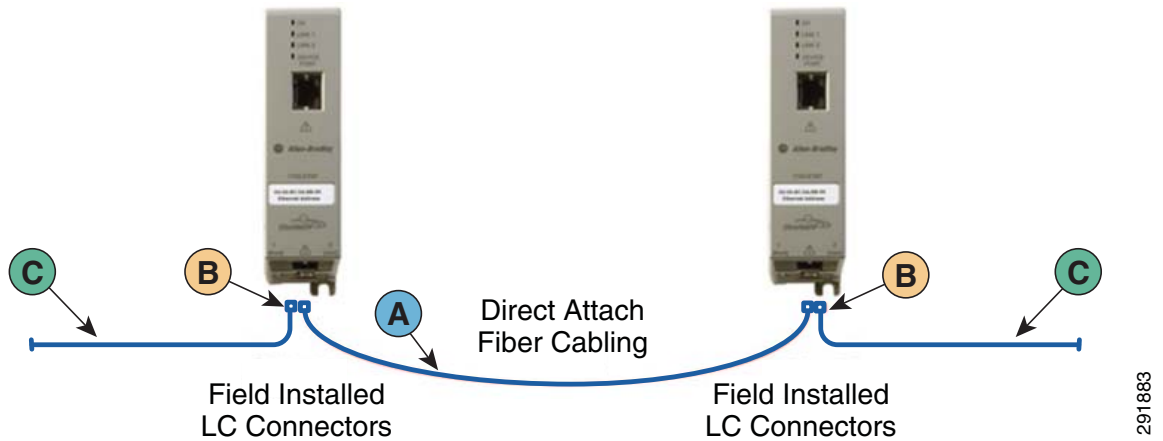

Table 2 Bill of Materials

| Designation | Part Number | Image | Description | Notes |
|-------------|-------------|-------|--|---|
| A | FXE10-10M1Y | | Opticom® OM3 multimode duplex patch cord (various lengths) | These fiber patch cords connect the ETAPs together by running from the fiber output of one ETAP to the fiber input of another ETAP. |
| B | FLDMCZAQY | | OM3 LC duplex Opticom connectors | Fiber connectors used to terminate field fiber entering and leaving the control panel that attaches the ETAPs to the Stratix switch. |
| C | FODPX06Y | | OM3 fiber optic distribution cable | Distribution cable used to connect the factory panel back to the control panel housing the Stratix switch. Cable construction depends on MICE level of environment. |

Panduit part numbers listed above.

.Another use for the ETAP is to function as a fiber-to-copper converter to allow for extending EtherNet/IP networks using the extended reach of fiber. The Allen-Bradley EtherNet/IP 1783-ETAP1F has one fiber and two copper ports. This combination of ports allows for converting from fiber to copper with the ports on the bottom of the ETAP, with an open copper Ethernet port for a local device to be connected to the face of the unit.

The layout in Figure 7 and the BOM in Table 3 represent the fiber connectivity necessary to complete this type of link.

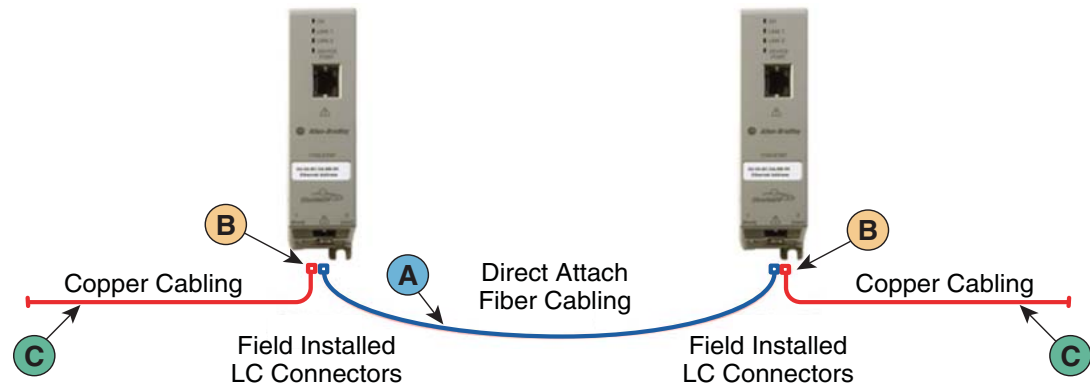

291883

Figure 7 Device-Level (Fiber to Copper) Reference Layout



291887

Table 3 Bill of Materials

| Designation | Part Number | Image | Description | Notes |
|-------------|--------------|---|--|--|
| A | FXE10-10M1Y |  | Opticom® OM3 multimode duplex patch cord (various lengths) | These fiber patch cords connect the ETAPs together by running from the fiber output of one ETAP to the fiber input of another ETAP. |
| B | MP5-88L |  | Cat 5E UTP modular plug | These copper plugs terminate on the ends of the copper horizontal/backbone cabling used to connect the ETAP to the Stratix switch. |
| C | PUP5504BU-UY |  | Cat 5E UTP copper cable | Copper cabling that connects the control panel back to the control panel housing the Stratix switch. Cabling construction depends on the MICE level. |

Panduit part numbers listed above.

Cell/Area Zone – Levels 0-2 – Control Panel

Control panels with PAC controllers, drives, I/O, and human-machine interfaces (HMIs) can be connected via Layer 2 access switches, such as the Allen-Bradley Stratix 8000, which are mounted within the control panel. To enable plantwide convergence, these Layer 2 access switches need to be connected to higher layer switches (for example, a Cisco Catalyst 3750 Series Switch) in one of various topology options, as shown in [Figure 8](#): redundant star, ring, or linear bus/star.

In each case, these control panel-mounted switches benefit from uplinks or rings formed by leveraging fiber connectivity. For clarification purposes, blue lines indicate fiber uplinks or connectivity, and red lines indicate copper connectivity.

Figure 8 CPwE Logical Framework—Cell/Area Zone Topologies

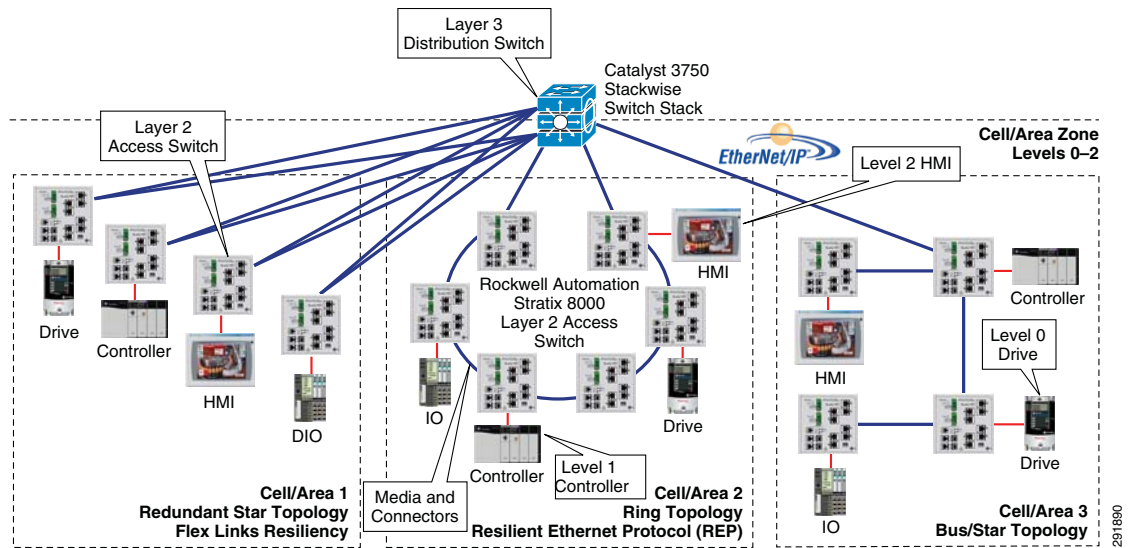
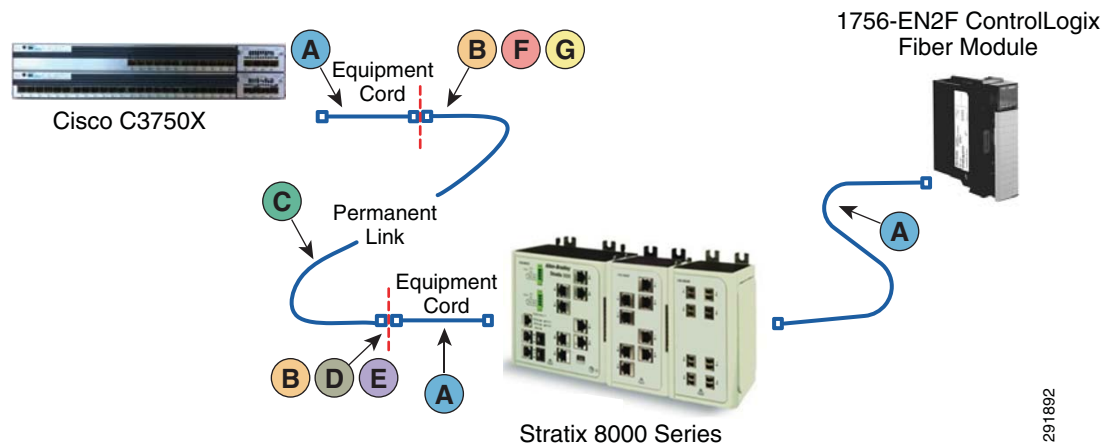

Figure 9 shows the Allen-Bradley Stratix 8000 switch mounted in the control panel with a Panduit® Mini-Com® fiber box providing a testable patching point for two uplink fiber cables. Pretested patch cords connect from the fiber box to small form-factor pluggable (SFP) modules installed in the Stratix switch. Figure 10 shows a schematic of this layout, and Table 4 lists the BOM.

Figure 9 Sample Control Panel Fiber Optic Deployment



Figure 10 Control Panel Reference Layout



291892

Table 4 Bill of Materials

| Designation | Part Number | Image | Description | Notes |
|-------------|--------------|-------|--|--|
| A | FXE10-10M1Y | | Opticom® OM3 multimode duplex patch cord (various lengths) | These fiber patch cords connect fiber uplinks and expansion links to the patch field that connects to the permanent link. |
| B | FLDMCZAQY | | OM3 LC duplex Opticam connectors | Fiber connectors used to terminate field fiber entering and leaving the control panel. |
| C | FODPX06Y | | OM3 fiber optic distribution cable | Distribution cable used to connect the panel back to the control panel housing the Stratix switch. The cable can be armored if required by MICE level. |
| D | CBXF12IW-AY | | Mini-Com® surface mount box | Houses the slack from the distribution cable after termination of the Opticam connectors. |
| E | CMDSAQLCZBL | | Mini-Com® fiber optic adapter module | Acts as a connection between the equipment cords and the field fiber-facing switches. |
| F | FCE1U | | Fiber optic rack mount enclosure | Fiber enclosure housed in the equipment rack in the micro data center to establish connectivity out to the plant floor fiber ring. |
| G | FAP6WAQDL CZ | | Opticom® fiber adapter panels (FAPs) | Fiber adapter panels used in the enclosure to provide patching to the plant floor. |

Panduit part numbers listed above.

Manufacturing Zone – Levels 0-2 – Network Zone Cabling

Layer 2 switching within the CPwE cell/area zone connects the levels 0–2 end devices to the manufacturing fiber network. One of the switches used to accomplish this is the Allen Bradley Stratix 8000 with copper and fiber expansion modules. This modular managed switch uses the current Cisco Catalyst switch architecture to provide secure integration within the overall enterprise. It allows easy setup and diagnostics from within the Rockwell Automation Integrated Architecture.

Figure 11 shows the Allen-Bradley 1783-MS10T managed switch with the 1783-MX08T copper expansion module and the 1783-MX08F fiber expansion module (this application guide discusses only the fiber portion of this switch). This fiber expansion module consists of eight 100BASE-FX LC fiber ports.

Figure 11 Sample Network Zone Fiber Optic Deployment



The main switch (1783-MS10T) has two empty uplink ports that can support an SFP LC transceiver that supports Gigabit Ethernet or Fast Ethernet networks (100/1000 Mbps). Several types of transceivers can be used, as shown in Table 5.

Table 5 Allen-Bradley SFP Modules Approved for Use with Stratix Switch

| Rockwell Automation Part Number | Description |
|---------------------------------|--|
| 1783-SFP100FX | 100BASE-FX multimode fiber transceiver |
| 1783-SFP1GSX | 1000BASE-SX multimode fiber transceiver |
| 1783-SFP100LX | 100BASE-LX singlemode fiber transceiver |
| 1783-SFP1GLX | 1000BASE-LX singlemode fiber transceiver |

Note: It is important not to use generic, non-industrial SFP modules with Stratix switches to avoid performance and reliability problems.

This guide describes the use of the 1000BASE-SX module (1783-SFP1GSX), as shown in Figure 12.

Figure 12 1000BASE-SX Module



This transceiver has an output wavelength of 850nm and can run on either 62.5µm fiber up to 275m, or 50µm fiber up to 1km over OM3 fiber. Note: once a fiber media type (50µm or 62.5µm) is chosen for the plant network, it should remain the same throughout the network.

The fiber expansion module (1783-MX08F) is a 100BASE-FX fixed module that also has both reach and link budget constraints. The reach limitation is 2000m for both the 50µm and 62.5µm fiber types. However, the link budgets differ. For 62.5µm fiber, the link budget associated with this transceiver is 8dB; and for 50µm fiber, the link budget associated with this transceiver is 4dB (fiber link budgets are discussed in [3. Fiber Optic Cabling Systems – Options and Considerations for Selection/Installation](#)).

Testing the link between the ETAP and Stratix switch can be accomplished by using TIA/EIA-526-14. Panduit provides the following best practices documents to ensure that fiber links are tested and cleaned properly according to the standards:

- Permanent Link Testing of Multimode and Singlemode Fiber Optic Cabling Systems (PN445)—
<http://www.panduit.com/groups/MPM-OP/documents/BestPractice/110255.pdf>
- Visual Inspection and Cleaning of Multimode and Singlemode Structured Cabling System Interconnect Components (PN446)—
<http://www.panduit.com/groups/MPM-OP/documents/BestPractice/109063.pdf>

Installation of the fiber cabling from the Level 3, Layer 3 MDC (see [Figure 4](#)) to the control panel housing the Stratix switch depends on the M.I.C.E. level of the environment through which the cable is pulled, as well as the type of fiber cabling being installed. The type of fiber optic cabling is usually either indoor armored cabling or distribution type cabling (see [Table 10](#) for fiber cabling types).

Cabling can either be pre-terminated (connectors are pre-installed) or raw (connectors are installed once the cabling is pulled into place, either field-polish termination or pre-polished cam termination type). When installing the fiber cabling system, always follow the Panduit best practices document, PN447B, Cable Preparation and Pulling Procedure: Best Practices for Fiber Optic Indoor Tight-Buffered Cable at the following URL:

<http://www.panduit.com/groups/MPM-OP/documents/InstallationInstruction/109056.pdf>.

[Figure 13](#) shows the layout and [Table 6](#) shows the BOM for fiber connectivity necessary to complete a connection between an ETAP and a Stratix 8000 switch.

Figure 13 Network Zone Reference Layout

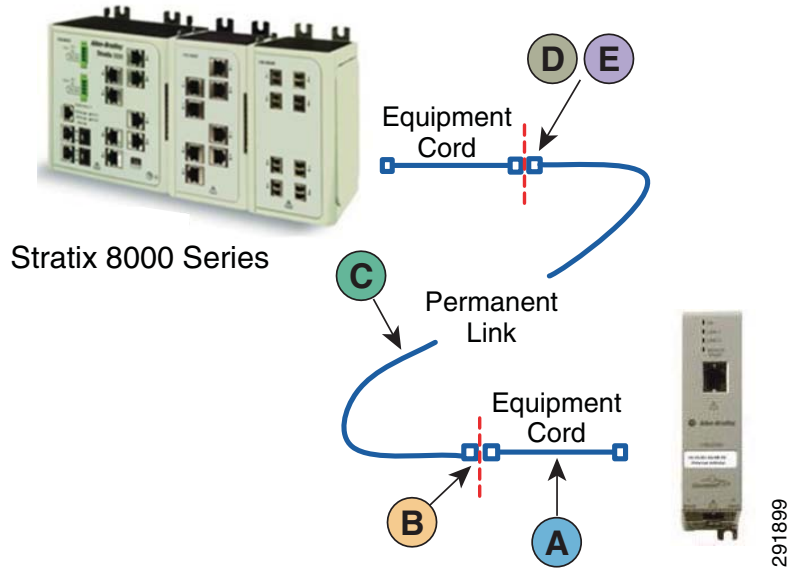

Table 6 Bill of Materials

| Designation | Part Number | Image | Description | Notes |
|-------------|-------------|-------|--|--|
| A | FXE10-10M1Y | | Opticom® OM3 multimode duplex patch cord (various lengths) | These fiber patch cords connect the Stratix 8000 fiber uplinks and expansion links to the patch field that connects to the permanent link. |
| B | FLDMCZAQY | | OM3 LC duplex Opticam connectors | Fiber connectors used to terminate field fiber entering and leaving the control panel. |
| C | FODPX06Y | | OM3 fiber optic distribution cable | Distribution cable used to connect the panel back to the control panel housing the Stratix switch. The cable can be armored if required by the MICE level. |
| D | CBXF12IW-AY | | Mini-Com® surface mount box | Houses the slack from the distribution cable after termination of the OptiCam connectors. |
| E | CMDSAQLCZBL | | Mini-Com® fiber optic adapter module | Acts as a connection between the equipment cords and the field fiber-facing switches. |

Panduit part numbers listed above.

Figure 14 shows the layout and Table 7 shows a BOM for fiber connectivity necessary to complete a connection between a Stratix 6000 and a Stratix 8000 switch.

Figure 14 Access Layer Extension Reference Layout

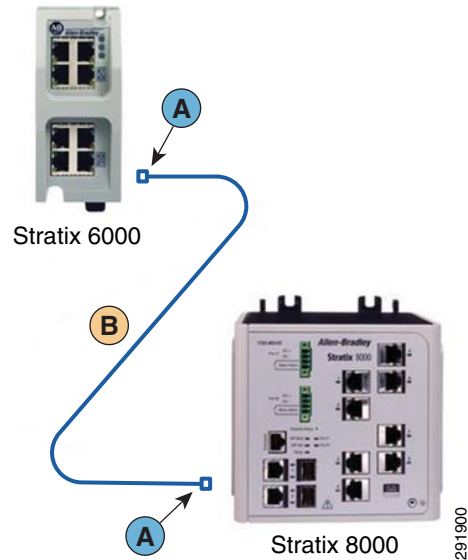

NOTE: In this scenario, the Stratix 6000 gigabit uplink must connect to one of the Stratix 8000 SFP uplinks, which leaves only one additional gigabit port available on the Stratix 8000. Note that using the uplink on the Stratix 8000 limits resiliency options. A maximum of two Stratix 6000s can be connected to a Stratix 8000 via fiber.

Table 7 Bill of Materials

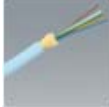
| | | | | |
|----------|-----------|---|------------------------------------|--|
| A | FLDMCZAQY |  | OM3 LC duplex Opticam connectors) | Fiber connectors used to terminate field fiber entering and leaving the control panel. |
| B | FODPX06Y |  | OM3 fiber optic distribution cable | Distribution cable used to connect the panel back to the control panel housing the Stratix switch. The cable type depends on the MICE level. |

Panduit part numbers listed above.

Manufacturing Zone – Levels 0-3 – Distribution to Access Layer

In the CPwE, the Cisco Catalyst 3750 and 4500 switch platforms are recommended for the distribution switch function, consolidating a range of cell/area zones, providing high availability, and supporting the scalable fiber-based connectivity. Distribution switches provide Layer 2 and 3 switching within Level 3 of the CPwE manufacturing zone. Both platforms support scalable fiber connectivity. The 3750-X Series has 12- and 24-port varieties. The 4500 Series has a variety of line cards supporting 12–48 ports of 100/1000Mbps SFP-based connectivity.

The switches can be equipped with 100BASE-X or 1000BASE-SX transceivers for the uplinks that are capable of transmitting up to 550m. Both platforms support 1 Gbps and 10 Gbps uplinks to core switches or firewalls.

Testing the link between the Layer 3 switch, such as the 3750-X, and Layer 2 switch (Stratix 8000) can be accomplished by using the TIA/EIA-526-14. To ensure that fiber links are tested and cleaned properly according to the standards, Panduit provides the following best practices documents:

- Permanent Link Testing of Multimode and Singlemode Fiber Optic Cabling Systems (PN445)—
<http://www.panduit.com/groups/MPM-OP/documents/BestPractice/110255.pdf>
- Visual Inspection and Cleaning of Multimode and Singlemode Structured Cabling System Interconnect Components (PN446)—
<http://www.panduit.com/groups/MPM-OP/documents/BestPractice/109063.pdf>

Installation of the fiber cabling from the MDC to the control panel housing the Stratix switch depends on the M.I.C.E. level of the environment through which the cable is pulled as well as the type of fiber cabling being installed. The type of fiber optic cabling is usually either indoor armored cabling, or it is distribution type cabling (see [Table 10](#) for fiber cabling types). Cabling can either be pre-terminated (connectors are pre-installed) or raw (connectors are installed after the cabling is pulled into place, either field-polish termination or pre-polished cam termination type). When installing the fiber cabling system, always follow the Panduit best practices document Cable Preparation and Pulling Procedure: Best Practices for Fiber Optic Indoor Tight-Buffered Cable (PN447B) at the following URL:

<http://www.panduit.com/groups/MPM-OP/documents/InstallationInstruction/109056.pdf>.

[Figure 15](#) shows the layout and [Table 8](#) shows the Bill of Materials for fiber connectivity necessary to complete connections between Layer 2 and Layer 3 switches.

For a complete listing of SFPs supported in a range of Cisco commercial switches, see the following:

- Cisco Small Form-Factor Pluggable Modules for Gigabit Ethernet Applications—
http://www.cisco.com/en/US/prod/collateral/modules/ps5455/ps6577/product_data_sheet0900aecd8033f885.pdf
- 100-Megabit Ethernet SFP Module Compatibility Matrix—
http://www.cisco.com/en/US/docs/interfaces_modules/transceiver_modules/compatibility/matrix/OL632702.pdf

Figure 15 Distribution to Access Layer Reference Layout

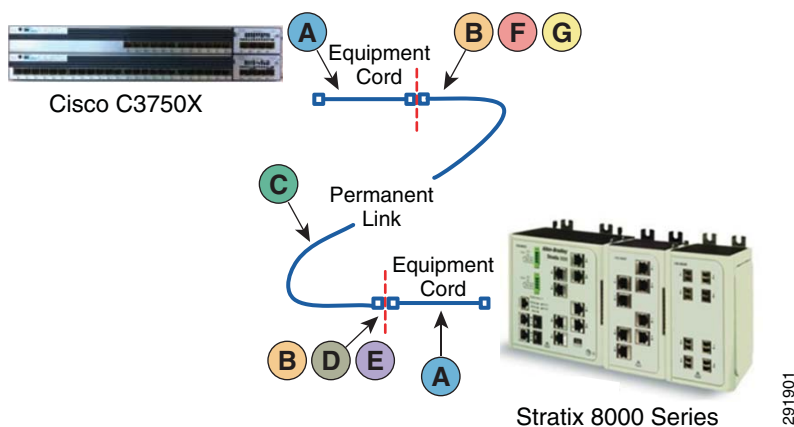

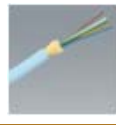





Table 8 Bill of Materials

| Designation | Part Number | Image | Description | Notes |
|-------------|-------------|---|--|--|
| A | FXE10-10M1Y |  | Opticom® OM3 multimode duplex patch cord (various lengths) | These fiber patch cords connect fiber uplinks and expansion links to the patch field that connects to the permanent link. |
| B | FLDMCZAQY |  | OM3 LC duplex Opticom connectors | Fiber connectors used to terminate field fiber entering and leaving the control panel. |
| C | FODPX06Y |  | OM3 fiber optic distribution cable | Distribution cable used to connect the panel back to the control panel housing the Stratix switch. The cable can be armored if required by MICE level. |
| D | CBXF12IW-AY |  | Mini-Com® surface mount box | Houses the slack from the distribution cable after termination of the Opticom connectors. |
| E | CMDSAQLCZBL |  | Mini-Com® fiber optic adapter module | Acts as a connection between the equipment cords and the field fiber-facing switches. |
| F | FCE1U |  | Fiber optic rack mount enclosure | Fiber enclosure housed in the equipment rack in the micro data center to establish connectivity out to the plant floor fiber ring. |
| G | FAP6WAQDLGZ |  | Opticom® fiber adapter panels (FAPs) | Fiber adapter panels used in the enclosure to provide patching to the plant floor. |

Panduit part numbers listed above.

Manufacturing Zone – Level 3 – Core to Distribution Layer

The Cisco Catalyst 6500/4500 Series Switches provide Layer 3 core switching and Layer 3 core routing in the manufacturing environment, delivering Gigabit Ethernet connectivity to Layer 3 switching within the micro data center. It can either be connected to the Cisco Catalyst 3750 Series Switch via fiber or copper cabling, depending on the transceivers deployed. [Figure 16](#) shows the layout and [Table 9](#) shows the Bill of Materials for fiber connectivity necessary to complete a connection between these switches.

Figure 16 Core to Distribution Layer Reference Layout

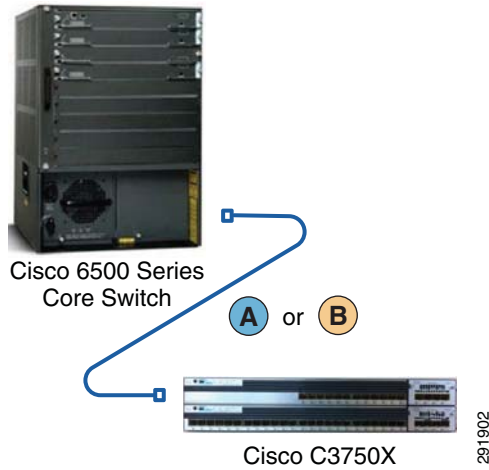



Table 9 Bill of Materials

| Designation | Part Number | Image | Description | Notes |
|-------------|-------------|---|--|---|
| A | FXE10-10M1Y |  | Opticom® OM3 multimode duplex patch cord (various lengths) | These fiber patch cords connect fiber uplinks and expansion links to the patch field that connects to the permanent link. |
| B | UTP5A3BU |  | UTP patch cord | Copper patch cords used to connect the switch ports of the Cisco Catalyst 6500 Series switch to the switch ports of the Cisco Catalyst 3750 switch. |

Panduit part numbers listed above.

3. Fiber Optic Cabling Systems – Options and Considerations for Selection/Installation

Network convergence time (healing, recovery, and so on) is a measure of how long it takes to detect a fault, find an alternate path, and then start forwarding network traffic across that alternate path. During the network convergence time, some portion of the traffic is dropped by the network because interconnectivity does not exist. If the convergence time is longer than the Rockwell Automation PAC connection timeout, the PAC may drop its connection to the industrial automation and control system (IACS) EtherNet/IP devices on the affected portion of the network, which may result in downtime and lost production. IACS network convergence time is important in evaluating network design choices that can impact IACS productivity.

During CPwE resiliency testing, Cisco and Rockwell Automation noticed a significant difference in network convergence time between topologies with fiber uplinks as compared to those deploying copper uplinks (all using the 1 Gb dual-use ports). This is because the IEEE specifies that a copper uplink can require up to 750ms to detect link loss (see [Zone Cabling Architecture Characteristics](#) for information on recovery and convergence times for fiber and copper uplinks).

Cisco and Rockwell Automation recommend the use of fiber media for inter-switch uplinks. This helps reduce network convergence time for IACS applications.

Environmental Considerations

It is recommended that network stakeholders assess the environmental factors of each area where the network is to be distributed (see Figure 17).

Figure 17 Sample Environmental Analysis Using the M.I.C.E. System

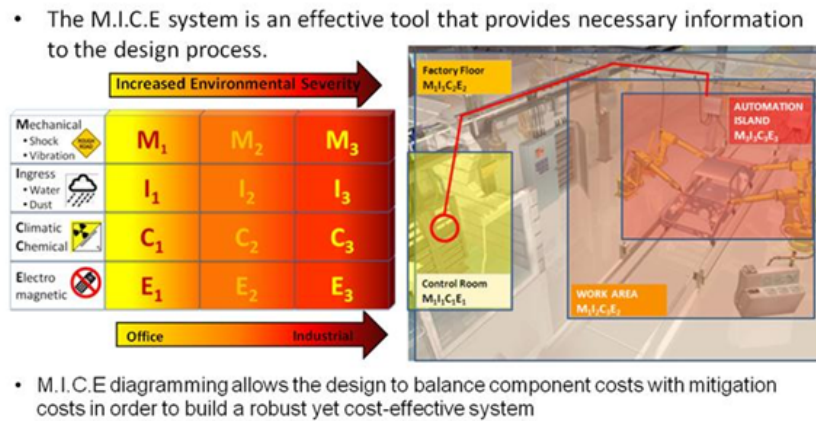

For this assessment, consider using M.I.C.E. analysis, a method recommended by global standards groups such as ANSI/TIA-568-C.0 and ODVA. This method is also found in ISO/IEC24702 and CENELEC EN50173-3, and a tutorial on this analytic tool can be found in ODVA's EtherNet/IP Media Planning and Installation Manual at the following URL:

http://www.odva.org/Portals/0/Library/Publications_Numbered/PUB00148R0_EtherNetIP_Media_Planning_and_Installation_Manual.pdf

The M.I.C.E. system is an effective tool that provides necessary information to the design process by assessing the Mechanical, Ingress, Chemical/Climatic, and Electromagnetic (M.I.C.E.) risk factors in each zone of a generic cable plant. M.I.C.E. diagramming allows the design to balance component costs with mitigation costs to build a robust yet cost-effective system. Each M.I.C.E. factor is graded on a severity scale from 1–3. The ratings allow for selecting appropriate media (such as armored fiber) or protective pathway arrangements to avoid risks from the environment affecting performance or reliability. By understanding the exposure levels, appropriate connectivity and pathways may be specified to ensure long term performance. For example, exposure to shock, vibration, and/or ultraviolet (UV) light may require use of armored fiber cabling suitable for outdoor environments.

Physical Media Considerations

Fiber Types

Three basic fiber media types are compatible with transceivers deployed in Stratix switches:

- OM1: 62.5/125µm graded index multimode
- OM2: 50/125µm graded index multimode (500 MHz-km)

- OM3: 50/125µm graded index multimode (2,000 MHz-km)
- OM4: 50/125µm graded index multimode (4,700 MHz-km)
- OS1: 9/125µm singlemode
ISO designations for multimode fiber (OM) and singlemode fiber (OS).

The physical geometry of the core and clad of each type of fiber are shown in [Figure 18](#).

Figure 18 Fiber Media Types

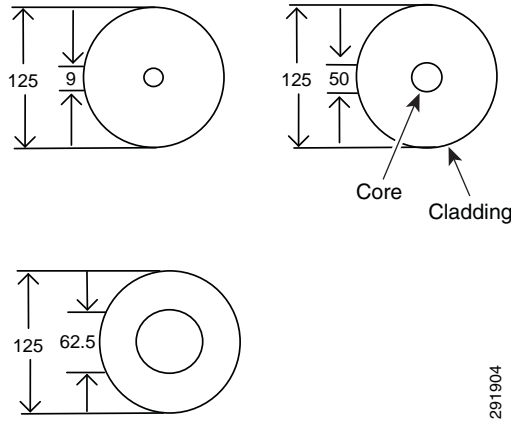

The capability of each fiber in terms of its bandwidth (and reach) is a function of transceiver type and the optical properties of the fiber used (in the list above, OS1 being the most capable and OM1 being the least).

In general, fiber is commonly used in backbone installations in the following situations:

- Faster convergence for network resiliency recovering from faults/changes
- Outdoor or between buildings
- When the distance is beyond the reach of copper (100m)
- For immunity from electromagnetic interference (EMI)

Singlemode fiber electronics are much more expensive than multimode equivalents and are generally deployed in long reach applications that are beyond the capability of their multimode counterparts (see [Table 10](#)). Also, fibers with a smaller multimode core size (50µm vs. 62.5µm) support higher bandwidth and longer reach applications.

Table 10 Fiber Optic Cabling Options

| Multimode | | Singlemode | |
|---|-------------------------|---|--|
| Pros | Cons | Pros | Cons |
| Lower total system cost • Lower cost transceivers • Lower cost connectors • Less complex to terminate in field | Higher fiber media cost | Higher bandwidth capabilities Longer reach Lower fiber media cost | Higher total system cost • Higher cost transceivers • Higher cost connectors • More complex to terminate in field |

[Table 11](#) illustrates the capability of each fiber system when deployed with an SFP (or fixed) transceiver in a switch (communicating with a like transceiver).

Table 11 Fiber Optic System Capabilities When Deployed with SFP Transceivers





| Transceiver | Switch Types | Reach in meters | | | |
|---|--|-----------------|------|------|--------|
| | | OM1 | OM2 | OM3 | OM4 |
| 100BASE-FX Multimode Fiber SFP or Fixed Port (Stratix 2000 & ETAPs) | Stratix 8000 / 8300 Stratix 2000 ETAPF1 & ETAPF2 | 2000 | 2000 | 2000 | NA |
| 100BASE-LX Singlemode Fiber SFP or Fixed Port | Stratix 8000 / 8300 | NA | NA | NA | 10,000 |
| 1000BASE-SX Multimode Fiber SFP | Stratix 8000 / 8300 Stratix 6000 | 275 | 550 | 550 | NA |
| 1000BASE-LX Singlemode Fiber SFP | Stratix 8000 / 8300 Stratix 6000 | 550 | 550 | 550 | 10,000 |

NOTE: Although OM1, OM2, and OM3 cabling at the 100BASE-FX layer does not influence the reach of the equipment, it is recommended to install OM2 or OM3 cabling to ensure that the reach of the application is at a maximum if there are future plans to upgrade to a 1000BASE-SX system.

Cable Designs

This section discusses basic fiber optic cable designs for plant network applications. Figure 19 places each cable type into a M.I.C.E. chart for use in determining the optimal fiber optic cable type for each plant network application.

Figure 19 Recommended Fiber Optic Cable Types with Common SFP Modules for Plant Network Applications

| | | | Increasing severity  | | | |
|-----------------|--------------------------|------------|--|--|---|---|
| | | | Fiber Type per MICE Level | | | |
| | | | M ₁ I ₁ C ₁ E ₃ | M ₁ I ₁ C ₂ E ₃ | M ₂ I ₂ C ₂ E ₃ | M ₂ I ₂ C ₂ E ₃ |
| SFP Module Type | Rockwell SFP Part Number | Fiber Type | Distribution Cable  | Indoor/Outdoor (Dielectric)  | Indoor Armored  | Gel-Free Outside Plant Armored Cable  |
| 100BASE-FX | 1783-SFP100FX | OM1 | F5DR6 [^] Y | FSNR6 [^] Y | FSPR6 [^] Y | FSWN6 [^] |
| | | OM2 | FSDR5 [^] Y | FSNR5 [^] Y | FSPR5 [^] Y | FSWN5 [^] |
| 100BASE-LX | 1783-SFP100LX | OS1/OS2 | FSDR9 [^] Y | FSNR9 [^] Y | FSPR9 [^] Y | FSWN9 [^] |
| 1000BASE-SX | 1783-SFP1GSX | OM1 | FSDR6 [^] Y | FSNR6 [^] Y | FSPR6 [^] Y | FSWN6 [^] |
| | | OM2 | FSDR5 [^] Y | FSNR5 [^] Y | FSPR5 [^] Y | FSWN5 [^] |
| | | OM3 | FODRX [^] Y | FONRX [^] Y | FOPRX [^] Y | FOWNX [^] |
| 1000BASE-LX/LH | 1783-SFP1GLX | OS1/OS2 | FSDR9 [^] Y | FSNR9 [^] Y | FSPR9 [^] Y | FSWN9 [^] |
| 1000BASE-ZX | GLC-ZX-SM-RGD | OS1/OS2 | FSDR9 [^] Y | FSNR9 [^] Y | FSPR9 [^] Y | FSWN9 [^] |

Panduit part numbers listed above.

[^] Length of patch cord in meters.

All part numbers shown are Duplex path cords.
Simplex available upon request.

291931

Non-armored fiber optic cabling is a standard cable that runs in a cabling basket or cable ladder internal to a controlled and protected environment (see [Figure 20](#)). This cabling type can also be installed in a duct system depending on the environment. Of all cable design options, non-armored fiber optic cabling is the most cost-effective choice, as it can withstand temperatures between -40° to 167°F (-40° to 75°C), and therefore can be deployed in a majority of cases.

Figure 20 Non-Armored Fiber Optic Cable

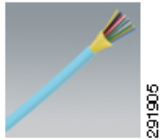

IP-rated fiber optic cabling is rated for high temperatures, is chemically resistant, and can be used in harsh environments (see [Figure 21](#)).

Figure 21 IP-rated Fiber Optic Cabling



Armored fiber optic cabling (both indoor and outside the plant) has a protected aluminum or metal housing around the fiber cable that helps protect the cabling from crushing or animal intrusion (see [Figure 22](#)). Aluminum interlocking armor provides superior crush resistance and eliminates the need for inner duct or conduit with a smaller pathway for improved design flexibility and lower installed cost.

Figure 22 Armored Fiber Optic Cabling

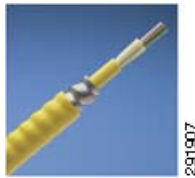

The compact design of armored cables and flexible buffer tubes allows for quick breakout and ease of routing inside of control panels and active zone enclosures (see [Figure 23](#)). Such cables allow for easy retrofit into existing industrial environments, eliminating the need for sophisticated and expensive pathways.

Figure 23 Armored Cable Bulkhead into Enclosure

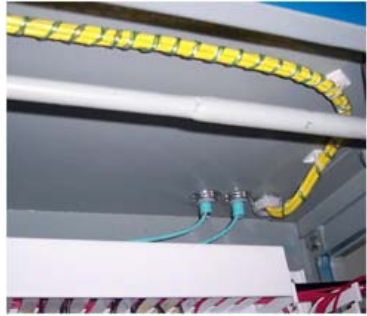

Slack loop sizes are determined by the diameter of the cable being installed, as shown in [Figure 24](#). Standards call for a bend radius of 10x the cable diameter during normal load, and 20x the cable diameter if the cable is under tension, as in during installation.

Figure 24 Sample Slack Loop



Another ruggedized fiber optic cable design is a two-fiber, ruggedized breakout cable that facilitates direct connector attachment of the cable (with pre-polished cam termination type connectors) to the transceiver ports on ETAPs or other devices (see [Figure 25](#)).

Figure 25 Two-Fiber, Ruggedized Breakout Cable



This design is basically “cable in a cable” and presents a rugged subunit for the connectors to attach to inside of the control panel. This cable typically serves as a point-to-point “direct attach” cable from a control panel to a control panel (typically housing ETAPs).

Connector Types

Pre-Polished

Pre-polished connectors (see [Figure 26](#)) are widely used in fiber optic termination applications. These connectors eliminate the need for end face polishing and adhesive to provide easier and faster installation, especially in remote areas and confined spaces.

Panduit® OptiCam® pre-polished cam style connectors have been tested to EIA/TIA fiber optic test procedures (FOTPs) that include operational temperature ranges of -40° to 158°F (-40° to +70°C), retention tests, as well as insertion loss and reflective loss. OptiCam® connectors can be re-terminated up to three times and can be reused if necessary when adds/moves/changes occur.

Figure 26 Sample Pre-Polished Connectors

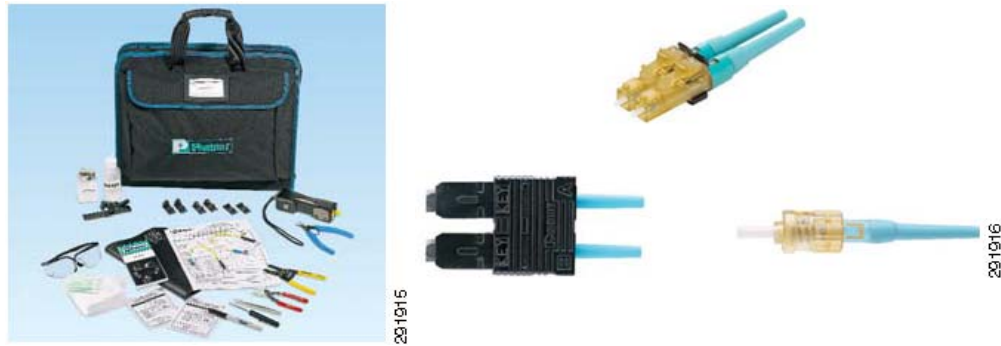

Field Terminated

Field-terminated connectors (see Figure 27) provide a rugged solution for telecommunication rooms, LANs, public networks, and fiber-to-the-desk applications. The glass is secured to the ferrule housing using a two-part epoxy solution, followed by a field polishing using proven, best practice tools and techniques. These connectors are used for equipment cross-connects or interconnects in backbone, horizontal, and work area applications for high-speed data transmissions.

Panduit Field-Polish Termination fiber connectors have been tested to EIA/TIA FOTPs, which include operational temperature ranges of -40° to 158°F (-40° to +70°C), retention tests, as well as insertion loss and reflective loss.

Figure 27 Sample Field-Terminated Connectors



Hardened Types

Two main connector systems are used in panel-to-panel EtherNet/IP links for fiber where special environmental requirements are stated (such as an IP-67 rating). Both of these connectors are intended for bulkhead applications where dust and water ingress are a concern.

Each of these connector systems conforms to requirements stated in ODVA specifications. These types of fiber interconnects are designed to address the more severe categories of M.I.C.E., typically an M3, I3, C3, and E3 (which describes a "typical" industrial space).

Also, both of these connector systems are widely available and are applicable to multiple fiber media types such as OMx graded index fiber, step index plastic optical fiber (POF) and hard clad silica (HCS), and OS1; and are generally application-agnostic.

Figure 28 shows the SC-RJ, which includes the following:

- IP67 rated to ensure protection from dust and water immersion
- SC duplex connection enables both single- and multi-mode fibers to be used as well as POF and HCS
- Not common with SFP modular 1G and 10/100M Ethernet Transceiver modules
- Push-on style latching lock
- ODVA compliant as plug to plug on cable

Figure 28 SC-RJ



Figure 29 shows the industrial LC, which includes the following:

- IP67 rated to ensure protection from dust and water immersion
- LC duplex connection enables both single- and multi-mode fibers to be used
- Common with SFP modular 1G and 10/100M Ethernet transceiver modules
- Bayonet-style mechanical lock
- Dual mounting bulkhead design
- ODVA compliant as plug to plug on cable

Figure 29 Industrial LC



Transceiver Considerations

Applicable Switches and Transceivers

The Allen-Bradley Stratix line of EtherNet/IP switches from Rockwell Automation (managed, unmanaged, and embedded) use IEEE 803-compliant SFP, multi-source agreement (MSA) transceivers as both switch ports and as uplinks. Stratix 2000 and ETAP switches use fixed-port versions of these transceivers.

Figure 30 shows the application points for both fiber uplinks and fiber switch points in a lineup consisting of a Stratix 8000 modular managed switch with a BASE-T switch port expansion module (1783-MX08T) and a BASE-S switch port expansion module (1783-MX08F), which include the following:

- Stratix fiber expansion module (1783-MX08F) 100BASE-FX switch ports with eight LC duplex connections
- Stratix 8000 base switch with two empty SFP slots for fiber uplinks to higher level switches (at far left).

Figure 30 Allen-Bradley Stratix 8000 Switch and Expansion Modules



Table 12 lists the switch ports and uplinks of the various switches.

Table 12 Switch Ports and Uplinks

| Switch Family | Models | Switch Ports and Uplinks | | | |
|-----------------------|----------------------------|--------------------------|------------|-----------|-----------|
| | | 100BASE-FX | 100BASE-LX | 1GBASE-SX | 1GBASE-LX |
| Stratix 8000 and 8300 | All | Yes | Yes | Yes | Yes |
| Stratix 6000 | 9 port | No | No | Yes | Yes |
| Stratix 2000 | 4 port and 7 port versions | Yes | No | No | No |
| ETAP | Both 3 port fiber | Yes | No | No | No |

Modular Transceiver Form-Factor (SFP)

The transceiver used in the Stratix switch line is an SFP LC transceiver supporting Gigabit or Fast Ethernet connections (see Figure 31). The SFP interface is defined in SFF-8074i, and is compatible to SFF-8472 (digital diagnostic interface for optical transceivers) using the 2-wire serial interface defined in the SFF-8472 MSA.

Figure 31 SFP LC Transceiver



Table 13 lists the transceiver part numbers and descriptions.

Table 13 Transceiver Part Number and Description

| Rockwell Automation Part Number | Description |
|---------------------------------|--|
| 1783-SFP100FX | 100BASE-FX multimode fiber transceiver |
| 1783-SFP1GSX | 1000BASE-SX multimode fiber transceiver |
| 1783-SFP100LX | 100BASE-LX singlemode fiber transceiver |
| 1783-SFP1GLX | 1000BASE-LX singlemode fiber transceiver |

For a complete listing of SFPs supported in a range of Cisco commercial switches, see the following:

- Cisco Small Form-Factor Pluggable Modules for Gigabit Ethernet Applications—
http://www.cisco.com/en/US/prod/collateral/modules/ps5455/ps6577/product_data_sheet0900aecd8033f885.html
- 100-Megabit Ethernet SFP Module Compatibility Matrix—
http://www.cisco.com/en/US/docs/interfaces_modules/transceiver_modules/compatibility/matrix/OL632702.pdf

NOTE: Rockwell Automation and Cisco Systems do not support the use of third-party SFP modules. The Cisco and Rockwell Automation SFPs are designed and conformance-tested by Cisco Systems and manufactured by certified suppliers.

LC Connector Interface / LC and other Patch Cords

The LC connector interface presents a small form factor (SFF) demountable interface for connection to SFP transceivers. The mechanical geometry for this connector is defined in both domestic (TIA FOCIS-10) and international (IEC 61754-20) standards. The LC connector footprint is approximately half the size of an SC connector. The LC has a back shell designed to accommodate standard 1.6mm to 3.0mm diameter cable designs. The standard construction of the LC connector consists of a spring-loaded, 1.25mm diameter zirconia ceramic ferrule housed in a thermoplastic connector back shell (see Figure 32).

Figure 32 LC Connector Interface



There are cases where legacy fiber is already present in a fiber installation with other connector types such as SC, ST, FC, MT-RJ, and so on. Panduit provides patch cords that allow patching to the legacy connector on one end to an LC connection suitable for connecting to Rockwell Automation LC connections or other LC connections in the system (see [Figure 33](#)).

Figure 33 Patch Cord Options

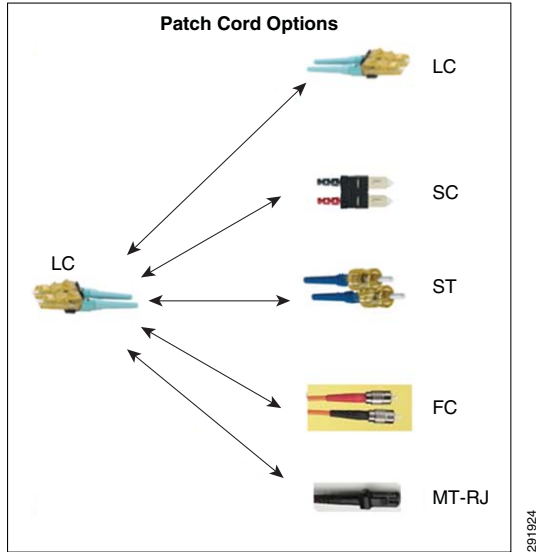

Table 14 shows various recommended fiber optic patch cord types.

Table 14 Recommended Fiber Optic Patch Cord Types with Common SFP Modules for Plant Network Applications

| SFP Module Type | Rockwell or Cisco SFP Part Number | Core Diameter | Patch Cord Type and Part Number | | | | |
|-----------------|-----------------------------------|---------------|---------------------------------|------------|------------|------------|-------------|
| | | | LC to LC | SC to LC | ST to LC | FC to LC | MT-RJ to LC |
| 100BASE-FX | 1783-SFP100FX | 62.5µm | F6E10-10M^Y | F6E3-10M^Y | F6E2-10M^Y | F6E4-10M^Y | F6D12-10M^Y |
| | | 50µm | F5E10-10M^Y | F5E3-10M^Y | F5E2-10M^Y | F5E4-10M^Y | F5D12-10M^Y |
| 100BASE-LX | 1783-SFP100LX | 9µm | F9E10-10M^Y | F9E3-10M^Y | F9E2-10M^Y | F9E4-10M^Y | F9D12-10M^Y |
| 1000BASE-SX | 1783-SFP1GSX | 62.5µm | F6E10-10M^Y | F6E3-10M^Y | F6E2-10M^Y | F6E4-10M^Y | F6D12-10M^Y |
| | | 50µm | F5E10-10M^Y | F5E3-10M^Y | F5E2-10M^Y | F5E4-10M^Y | F5D12-10M^Y |
| | | 10 Gig 50µm | FXE10-10M^Y | FXE3-10M^Y | FXE2-10M^Y | FXE4-10M^Y | FXD12-10M^Y |
| 1000BASE-LX /LH | 1783-SFP1GLX | 9µm | F9E10-10M^Y | F9E3-10M^Y | F9E2-10M^Y | F9E4-10M^Y | F9D12-10M^Y |
| 1000BASE-ZX | GLC-ZX-SM-RGD | | F9E10-10M^Y | F9E3-10M^Y | F9E2-10M^Y | F9E4-10M^Y | F9D12-10M^Y |

Panduit part numbers listed above.

^ Length of patch cord in meters.

All part numbers shown are Duplex patch cords.

Simplex available upon request.

Fiber Optic Loss/Power Budgets

Link Power Loss Budgeting for Installed Cabling

The optical performance expectations for optical channel links are specified in commercial cabling standards such as TIA-568-C.1 and IEC 11801. These standards specify the expected power loss in installed fiber cabling based on fiber type, number of mated pairs of connectors deployed, and number of fusion splices (if present). This assures that channel links comprising legacy fiber types, lower bandwidth fibers, or channels containing numerous connector interfaces or splices operate reliably.

Most power meter/light source (PMLS) test sets use these cable standards to verify channel link compliance. This method of estimated link budget can be illustrated by considering the following example.

The fiber optic channel under scrutiny is a 75m permanent link between a Cisco Catalyst 3750 Series Switch and Stratix 8000 switch supporting 1Gb/s, 850nm transmission over an OM2 cable. The channel contains two connector pairs: one in the micro data center where the Cisco switch resides, and one in the zone enclosure where the Stratix resides (see Figure 34).

NOTE: In the field, both core size cables (62.5µm and 50µm) may be used for both 850nm and 1300nm wavelengths.

Figure 34 Sample Two Connector Pair EtherNet/IP Fiber Cabling Deployment

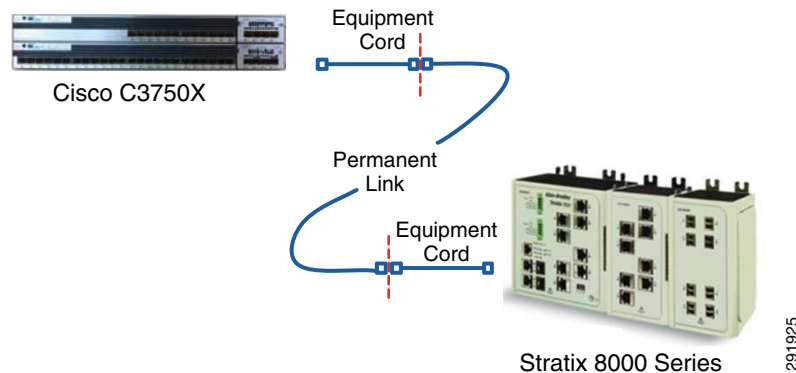

The ANSI/TIA/EIA-568-C standard designates the allowable attenuation coefficients for the various cable types along with the loss for fixed connectors as 0.75dB per mated pair, and the allowable loss for fusion splices as 0.30dB per splice. These values are essential in calculating link loss. According to TIA and IEC standards, the maximum cable attenuation coefficient is 3.5dB/km. From this the maximum allowable loss for this link can be calculated as follows:

$$\text{Link budget} = (3.5\text{dB/km} \times 0.075 \text{ km}) + (0.75\text{dB} \times 2 \text{ connector pairs}) = 1.76\text{dB}$$

Given this calculated maximum allowable budget, it can be readily determined whether the measured permanent link loss exceeds the industry allowable optical penalty as specified in TIA and IEC cabling standards.

In an instance where control panels are built to service device-level rings with ETAPs, the following “direct attach” scenario would involve direct cabling runs between ETAPs resident within separate control panels, where a “structured cabling” approach using patch panels and patch cords is not used; and therefore, no mated pairs of connectors in the cable plant (see Figure 35). Such direct attach cabling is used in deployments where a structured cabling model provides little or no value; that is, where installations are small and/or static over the life of the installation.

Figure 35 Sample Direct Attach EtherNet/IP Fiber Cabling Deployment

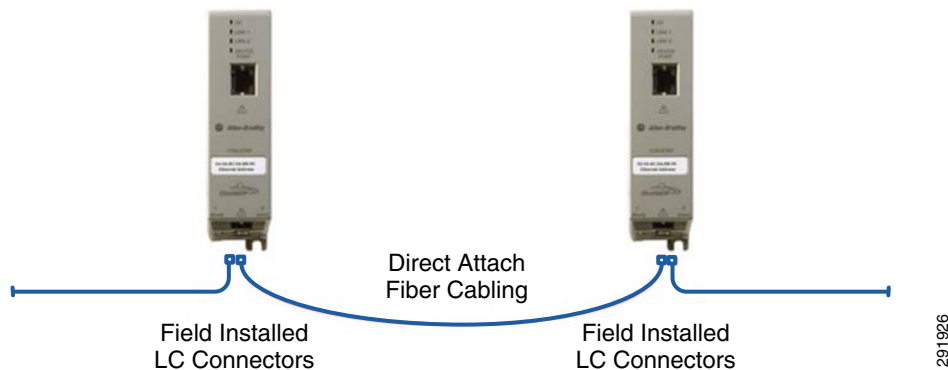

This example assumes that the ETAPs shown are resident in physically separate control panels; otherwise (as in the case of multiple ETAPs per panel), pre-terminated and precise length jumper cordage can be deployed between the ETAPs mounted on the DIN rail.

For the example above, if the length of fiber deployed between the control panels that house the ETAPs is 75 meters, the maximum expected loss for this link can be calculated as follows:

$$\text{Link budget} = (3.5\text{dB/km} \times 0.075 \text{ km}) + (0.75\text{dB} \times \text{zero connector pairs}) = 0.26\text{dB}$$

In this case, the fiber attenuation is the only contributor to the overall link power budget.

Transceiver Power Budgets

The overall power budget for an optical channel link is determined by the applicable IEEE 802.3 standard. This is a function of the combination of transceiver technology and media chosen. The goal of a designed link is to use available output power from the transceiver source (specified at a minimum) in concert with fiber attenuation and connector losses to maintain a power margin above the noise floor specified in the receiver side of the transceiver. The optical budget serves as a useful estimation to determine whether sufficient optical output power remains on the receiver side of an optical link.

Between the transmitter and receiver, segments of fiber are deployed that are connected by fiber connectors and/or splices (see Figure 36). Each of these elements contributes to overall loss of signal and pushes the link loss towards the noise floor of the receiver. The difference in the transmitter output (at worst case) and the receiver sensitivity (at worst case) is called the power budget for the channel, with larger power budgets preferred to smaller budgets. It is a stated and explicit goal for the loss budget for the installed cabling to be sufficient to produce adequate margin (see <http://www.thefoa.org/tech/lossbudg.htm> for examples of how to calculate fiber optic loss budgets).

Figure 36 Illustration of Loss Across Fiber Cabling Channel

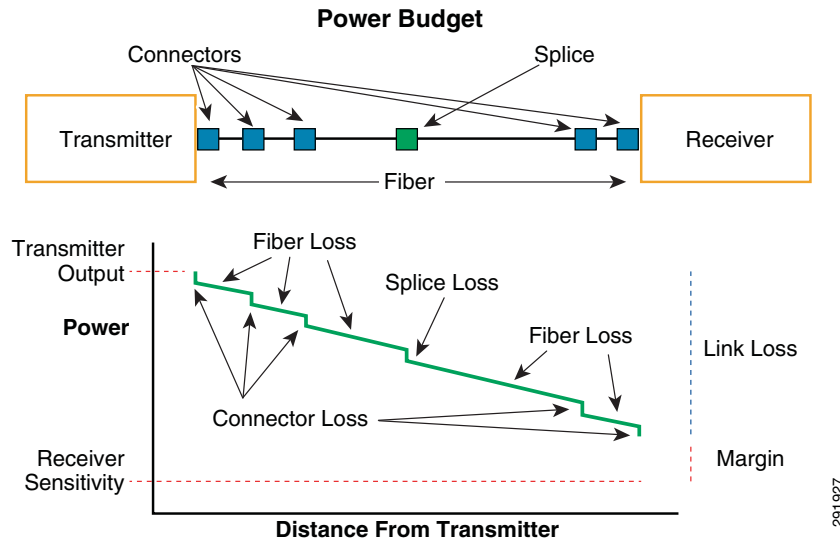

Table 15 shows the various power budgets for four Stratix switch deployments using each of the four available transceiver technologies.

Table 15 Optical Power Budgets for Four Stratix Switch Deployments

| Transceiver | Optical Power Budget (dB) | | | |
|--|---------------------------|-----|-----|-----|
| | OM1 | OM2 | OM3 | OS1 |
| 100Base-FX Multi-mode Fiber SFP or Fixed Port (Stratix 2000 and ETAPs) | 8 | 4 | 4 | NA |
| 100Base-LX Single-mode Fiber SFP | NA | NA | NA | 10 |
| 1000Base-SX Multi-mode Fiber SFP | 75 | 75 | 75 | NA |
| 1000Base-LX Single-mode Fiber SFP | NA | NA | NA | 8 |

Table 16 shows the various fiber media types available along with the maximum reach capabilities of each at the 1 Gb transmission speeds.

Table 16 Fiber Optic Media Types and Properties

| Fiber Type | Core/Cladding | Wavelength (nm) | Max Loss (dB/km) | Minimum EMBc ((Mhz*km) | Max Reach @ 1G (m) | Max Reach @ 10G (m) |
|------------|---------------|-----------------|------------------|------------------------|--------------------|---------------------|
| OM1 | 62.5/125 | 850 | 3.5 | 200 | 270 | 33 |
| | | 1300 | 1.5 | ----- | 550 | 300 |
| OM2 | 62.5/125 | 850 | 3.5 | 500 | 550 | 82 |
| | | 1300 | 1.5 | ----- | 550 | 300 |
| OM2+ | 62.5/125 | 850 | 3.5 | 950 | 750 | 150 |
| | | 1300 | 1.5 | ----- | 600 | 300 |
| OM3 | 50/125 | 850 | 3.5 | 2000 | 1000 | 300 |
| | | 1300 | 1.5 | ----- | 600 | 300 |
| OM4 | 50/125 | 850 | 3.0 | 5000 | 1040 | 500 |
| | | 1300 | 1.5 | ----- | 600 | 300 |
| OS1 | 9/125 | 1310-1625 | 0.35 | NA | NA | NA |

4. Link Testing

Channel

A fiber channel consists of patch cords plus all the components of the permanent link. The channel is constructed from components compatible with the channel length and application losses that it is required to support. Each channel is represented by a pair of fibers that form an individual circuit, with each individual circuit having a transmit side and a receive side.

All segments in the cabling system should be the subject of link loss testing. A link segment consists of the fiber cable media and connectivity, such as fiber connectors, adapters, splice points, and so on, connecting different segments of the network. The link loss measurement for a network segment includes the insertion loss of connectors at the panels (termination bulkheads) on either end of the link, but does not include the attenuation of any short jumpers attached to line terminating electronics or the performance of the connector at the equipment interface. Although the channel is defined as all of the components in the permanent link plus additional jumpers attached to line terminating electronics, only the permanent link is measured against the standards expectations.

Permanent Link

The permanent link segment is the cabling infrastructure element of a channel. The permanent link is typically seen as the fiber cabling media and connectivity that connects patch panel to patch panel, as well as the connectivity resident in the patch panels themselves. A permanent link does not include any patch cords to the line terminating electronics. Testing of a permanent link should be completed before any patch cords are connected to the panels to complete the channel.

ISO/IEC and TIA standards define the permanent link as the permanent fiber cabling infrastructure over which the active equipment must communicate. This does not include equipment patch cords to connect the active network devices in control panels or the patch cords in other switch patching areas.

ISO/IEC and TIA standards define permanent link testing to verify the performance of the fixed (permanent) segments of installed cabling as accurately as possible.

Unless otherwise stated, all permanent link loss testing of a segment shall be performed with a handheld power meter/source. This equipment measures link attenuation, which is the most important performance parameter when installing components.

For backbone cabling, it is recommended that permanent link testing be performed for all links at both specified wavelengths. Multimode fibers should be tested in one direction at 850nm (the SX operating window) and additionally at 1300nm to account for fiber attenuation differences due to wavelength to reveal potential issues associated with installation practice. Similarly for LX applications, window testing should first be done at the application operating wavelength and the second window at the higher wavelength (1550nm).

Significant differences in link results between these windows can aid in troubleshooting the direction in the case of failing links. Link failures predominately at the first window may indicate problems with connector systems, while second window failures may indicate fiber macrobend sites in the installed cabling; that is, large-radius bends in the cable that can cause incremental added attenuation.

The Panduit best practices document Permanent Link Testing of Multimode and Singlemode Fiber Optic Cabling Systems (PN445) at <http://www.panduit.com/groups/MPM-OP/documents/BestPractice/110255.pdf>, provides

information on testing of the fiber permanent links used to connect Stratix switches. This document also outlines the Panduit recommended procedures for testing multimode and singlemode structured cabling system links.

Minimum Testing Recommendations

All segments in the cabling system should be the subject of link loss testing according to TIA/EIA and IEC standards. This testing ensures the quality and reliability of the installed link.

Unless otherwise stated, all permanent link loss testing of a segment shall be performed with a handheld power meter/source. This equipment measures link attenuation, which is the most important performance parameter when installing components. Optical time domain reflectometer (OTDR) testing is not a requirement in fiber certification, and should be used for troubleshooting failed links only.

For further testing reference, see the Panduit best practices document Permanent Link Testing of Multimode and Singlemode Fiber Optic Cabling Systems (PN445) at <http://www.panduit.com/groups/MPM-OP/documents/BestPractice/110255.pdf>, or the Panduit Industrial Ethernet Physical Infrastructure Reference Architecture Design Guide, available at the following URL: <http://www.panduit.com/Solutions/IndustrialAutomation/index.htm>.

Troubleshooting Considerations

OTDR testing is not a requirement in fiber certification. In fact, this basic fiber certification (Tier 1) with a power meter and light source is the only type of testing required by TIA-568B for premises cabling. This test method measures end-to-end insertion loss by using a power meter and light source. If the attenuation is within the limits of the allotted power budget, the system works. Panduit does not recommend testing links via the OTDR method.

Many individuals responsible for performing link testing have questioned whether they should perform OTDR testing for fiber cabling in light of the publication of TIA TSB 140, "Additional Guidelines for Field-Testing Length, Loss, and Polarity of Optical Fiber Cabling Systems". Some also question whether this type of testing can supplant traditional PMLS testing.

OTDR testing cannot replace Tier 1 PMLS testing as the only type of testing required by domestic and international standards bodies for the commissioning testing for of DC permanent links.

Tier II OTDR testing (extended testing), is not a substitute for PMLS testing, but is optional and complementary and is best deployed for troubleshooting potentially discrepant permanent links. In addition to link loss, OTDR testing reveals component insertion loss and reflectivity of connectors, splices, and other fiber attenuation discontinuities in the link. The results of this type of testing can be used to validate individual component specifications.

Together, PMLS and OTDR testing provide both the absolute loss measurements in comparison with the loss budget, and individual measurement of events on a fiber link. Industry standards require Tier 1 (PMLS) testing as the minimum regimen for a compliant installation. OTDR testing is performed at the discretion of the network owner and system designer.

For information on the cleaning of connectors used to connect to Stratix switches, see the Panduit best practices document Visual Inspection and Cleaning of Multimode and Singlemode Structured Cabling System Interconnect Components (PN446) at the following URL: <http://www.panduit.com/groups/MPM-OP/documents/BestPractice/109063.pdf>. This document outlines the Panduit recommended procedures for visual inspection and cleaning of multimode and singlemode structured cabling system interconnect components (connectors and adapters).

For information on the cleaning of transceivers used in Stratix switches, see the Panduit best practices document Best Practice for Cleaning Multimode and Singlemode Transceiver Optics (PN541) at the following URL:
http://www.panduit.com/groups/MPM-OP/documents/BestPractice/CMSCONT_037822.pdf.
 The purpose of this document is to communicate Panduit's recommended best practices for cleaning lens (multimode) and fiber stub type (singlemode) transceivers.

5. Service and Support

Rockwell Automation Network and Security Services

As manufacturers move toward network convergence, challenges such as the following can present themselves if not managed properly:

- Security risks—Internal and external, malicious (worms and viruses) or accidental (users with inappropriate access rights)
- Unsecure remote access—Open access, no limitations
- One network, multiple owners—Blurred ownership and differing goals

To help you manage these challenges, Rockwell Automation Network and Security Services offers a knowledgeable team, expertly trained in both manufacturing and IT. The Rockwell Automation converged team has the domain expertise to provide you with the appropriate services your industrial control and information networks require.

Understanding how your network and security infrastructure, policies, and procedures affect your plant, and the personnel who use them every day, is Rockwell Automation's job.

Rockwell Automation field engineers and consultants are trained and equipped to assess, design, implement, audit, and manage your network and security infrastructure. The complete Rockwell Automation portfolio of network and security services is delivered globally, and is structured to augment your staff or manage turnkey network/security solutions with Rockwell Automation partners, providing cost-effective methods to help attain the highest return on your investment (see [Figure 37](#)).

Figure 37 Rockwell Automation Portfolio of Services

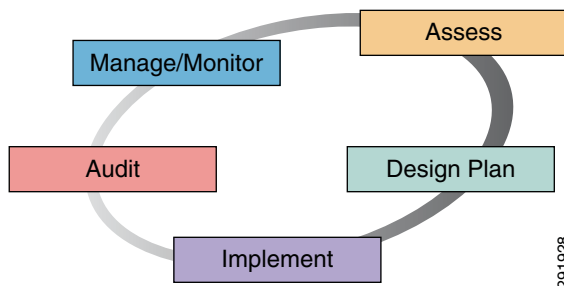

The Rockwell Automation converged network and security team has the following:

- Knowledge of manufacturing applications and their dependency on the infrastructure and possible impact on the overall manufacturing process
- Awareness of manufacturing security consequences

- Understanding of the differences between bandwidth and latency
- Knowledge of how each layer of the OSI model affects the performance of your system
- Experience with all types of manufacturing networks: EtherNet/IP, ControlNet, DeviceNet, DH+, Remote IO, Fieldbus, and other automation industry networks
- Involvement in, and awareness of, national and global standards committees, such as the Department of Homeland Security, Idaho National Labs, ISA 99, and NIST 800-82
- Awareness of traditional IT policies and the impact they can have on the plant floor
- Capability to provide wired and wireless network solutions

Panduit Certified Installer Program

Panduit's Certified Installer program focuses on the installation and delivery of Panduit copper and fiber cabling systems in compliance with industry standards and Panduit requirements, to provide a more secure physical infrastructure. Panduit Certified Installers (PCIs) receive ongoing training and support to broaden skills and enhance value.

Upon completion of Panduit certification requirements, a PCI can offer the Panduit Certification PlusSM System Warranty. Certified system installations performed by a PCI not only ensure sustainable performance, but ultimately provide customers a lower cost of ownership and decreased risk associated with their infrastructure (see [Figure 38](#)).

Figure 38 Panduit Certified Installer Program Benefits



- Global network of Panduit Certified Installers (PCI), provides field tested deployment of structured cabling system infrastructures.
- PCI installations will ensure performance with lower cost of ownership and warranty options
- Panduit Certified Installers have been supplying installation expertise for fiber and copper for RA Networks

291929

Appendix — List of Applicable Fiber Standards

- TIA/EIA-568-C.1: Commercial Building Telecommunications Cabling Standard - Part 1, General Requirements
- TIA/EIA-568-C.3: Commercial Building Telecommunications Cabling Standard - Part 3, Optical Fiber Cabling Components Standard
- TIA EIA-569-A: Commercial Building Standard for Telecommunications Pathways and Spaces
- ISO/IEC 11801: Information Technology: Generic Cabling for Customer Premises
- TIA 1005: Telecommunications Infrastructure Standard for Industrial Premises

- ANSI/TIA/EIA-310-D: Cabinets, Racks, Panels, and Associated Equipment
- TIA/EIA-4750000-C: Generic Specifications for Fiber Optic Connector Sets
- TIA/EIA-604-10: (FOCIS-10) Simplex and Duplex, Single Mode and Multi Mode Connector
- ANSI/TIA/EIA-492-AAAA-A: Detail Specification for 62.5µm Core Diameter/125µm Cladding Diameter Class Ia Graded Index Multimode Optical Fibers
- ANSI/TIA/EIA-492- AAAB: Detail Specification for 50 µm Core Diameter/125µm Cladding Diameter Class Ia Graded Index Multimode Optical Fibers
- ANSI/TIA/EIA -492AAAC-A: Detail Specification for 850-nm Laser-Optimized, 50-µm Core Diameter/125-µm Cladding Diameter Class Ia Graded-Index Multimode Optical Fibers
- ANSI/TIA/EIA-492-CAAA: Detail Specification for Class IVa Dispersion-Unshifted Singlemode Optical Fibers
- TIA/EIA-455: Standard Test Procedures for Fiber Optic Fibers, Cables, Transducers, Connecting and Terminating Devices
- ANSI/TIA/EIA-526-7 OFSTP-14A: Optical Power Loss Measurements of Installed Multimode Fiber Cable Plant
- ANSI/TIA/EIA-526-7 OFSTP 7: Measurement of Optical Power Loss of Installed Singlemode Fiber Cable Plant
- IEC 61300-3-35: Fiber optic interconnecting devices and passive components - Basic test and measurement procedures - Part 3-35: Examinations and measurements - Fibre optic connector endface visual and automated inspection
- ISO/IEC 14763-3: Implementation and Operation of Customer premise Cabling - Part 3. Testing of Optical Fiber Cabling

Panduit is a world-class developer and provider of leading-edge solutions that help customers optimize the physical infrastructure through simplification, agility and operational efficiency. Panduit's Unified Physical InfrastructureSM (UPI) based solutions give enterprises the capabilities to connect, manage and automate communications, computing, power, control and security systems for a smarter, unified business foundation. Strong relationships with technology leaders complemented with its global staff and unmatched service and support, make Panduit a valuable and trusted partner.

www.panduit.com.

| | | | |
|--|---|----------------------------------|------------------------------|
| US and Canada World Headquarters Tinley Park, IL 60487 cs@panduit.com 800.777.3300 | Europe, Middle East, and Africa 44.208.601.7200 | Latin America 52.33.3777.6000 | Asia Pacific 65.6305.7575 |
|--|---|----------------------------------|------------------------------|

Cisco is the worldwide leader in networking that transforms how people connect, communicate and collaborate. Information about Cisco can be found at www.cisco.com. For ongoing news, please go to <http://newsroom.cisco.com>. Cisco equipment in Europe is supplied by Cisco Systems International BV, a wholly owned subsidiary of Cisco Systems, Inc.

www.cisco.com

| | | |
|--|---|---|
| Americas Headquarters Cisco Systems, Inc. San Jose, CA | Asia Pacific Headquarters Cisco Systems (USA) Pte. Ltd. Singapore | Europe Headquarters Cisco Systems International BV Amsterdam, The Netherlands |
|--|---|---|

Rockwell Automation is a leading provider of power, control and information solutions that enable customers to get products to market faster, reduce their total cost of ownership, better use plant assets, and minimize risks in their manufacturing environments.

www.rockwellautomation.com

| | | |
|--|--|--|
| Americas: Rockwell Automation 1201 South Second Street Milwaukee, WI 53204-2496 USA Tel: (1) 414.382.2000, Fax: (1) 414.382.4444 | Asia Pacific: Rockwell Automation Level 14, Core F, Cyberport 3 100 Cyberport Road, Hong Kong Tel: (852) 2887 4788, Fax: (852) 2508 1846 | Europe/Middle East/Africa: Rockwell Automation Vorstlann/Boulevard du Souverain 36 1170 Brussels, Belgium Tel: (32) 2 663 0600, Fax: (32) 2 663 0640 |
|--|--|--|

© 2011 Cisco Systems, Inc, Panduit, and Rockwell Automation, Inc. All rights reserved.

Publication ENET-TD003A-EN-E — November 2011

